

This handbook contains a number of different sections. The table of contents below will help you find the beginning of each section where, in the case of the major sections, a further table of contents will help you find the specific subject required.

- 03** FOREWORD
- 07** SAFETY FIRST
- 16** WARNING LABELS
- 18** PARTS IDENTIFICATION
- 23** SERIAL NUMBERS
- 25** GENERAL INFORMATION
- 109** HOW TO RIDE THE MOTORCYCLE
- 123** ACCESSORIES, LOADING AND PASSENGERS
- 129** MAINTENANCE
- 187** CLEANING AND STORAGE
- 199** WARRANTY
- 211** SPECIFICATIONS
- 217** SPECIFICATIONS
- 223** SPECIFICATIONS
- 229** INDEX
- 234** APPROVAL INFORMATION

Owner's Handbook



Warning

This Owner's Handbook, and all other instructions that are supplied with your motorcycle, should be considered a permanent part of your motorcycle and should remain with it even if your motorcycle is subsequently sold.

All riders must read this Owner's Handbook and all other instructions which are supplied with your motorcycle, before riding, in order to become thoroughly familiar with the correct operation of your motorcycle's controls, its features, capabilities and limitations.

Do not lend your motorcycle to others as riding when not familiar with your motorcycle's controls, features, capabilities and limitations can lead to an accident.

Thank you for choosing a Triumph motorcycle. This motorcycle is the product of Triumph's use of proven engineering, exhaustive testing, and continuous striving for superior reliability, safety and performance.

Please read this Owner's Handbook before riding in order to become thoroughly familiar with the correct operation of your motorcycle's controls, its features, capabilities and limitations.

This Owner's Handbook includes safe riding tips, but does not contain all the techniques and skills necessary to ride a motorcycle safely.

Triumph strongly recommends that all riders undertake the necessary training to ensure safe operation of this motorcycle.

This Owner's Handbook is available from your local dealer in:

- ▼ English
- ▼ US English
- ▼ Arabic
- ▼ Chinese
- ▼ Dutch
- ▼ French
- ▼ German
- ▼ Italian
- ▼ Japanese
- ▼ Portuguese
- ▼ Spanish
- ▼ Swedish
- ▼ Thai
- ▼ Finnish (available online from www.triumphmotorcycles.com).

The languages available for this Owner's Handbook are dependent on the specific motorcycle model and country.

Talk to Triumph

Our relationship with you does not end with the purchase of your Triumph. Your feedback on the buying and ownership experience is very important in helping us develop our products and services for you.

Please help us by ensuring your authorized Triumph dealership has your email address and registers this with us. You will then receive an online customer satisfaction survey invitation to your email address where you can give us this feedback.

Your Triumph Team.

Warnings, Cautions and Notes

Throughout this Owner's Handbook particularly important information is presented in the following form:

Warning

This warning symbol identifies special instructions or procedures, which if not correctly followed could result in personal injury, or loss of life.

Caution

This caution symbol identifies special instructions or procedures, which, if not strictly observed, could result in damage to, or destruction of, equipment.

Note

This note symbol indicates points of particular interest for more efficient and convenient operation.

Warning Labels



At certain areas of the motorcycle, the symbol (above) can be seen. The symbol means 'CAUTION: REFER TO THE HANDBOOK' and will be followed by a pictorial representation of the subject concerned.

Never attempt to ride the motorcycle or make any adjustments without reference to the relevant instructions contained in this handbook.

For more information on the location of all labels showing this symbol, see page 16. Where necessary, this symbol will also appear on the pages containing the relevant information.

Maintenance

To ensure a long, safe and trouble free life for your motorcycle, maintenance should only be carried out by an authorized Triumph dealer.

Only an authorized Triumph dealer will have the necessary knowledge, equipment and skills to maintain your Triumph motorcycle correctly.

To locate your nearest authorized Triumph dealer, visit the Triumph web site at www.triumph.co.uk or telephone the authorized distributor in your country. Their address is given in the service record book that accompanies this handbook.

Off-road Use

The motorcycles are designed for on-road and light off-road use. Light off-road use includes use on unpaved, dirt or gravel roads, but does not include riding on any motocross course, any off-road competition (such as motocross or enduro riding), or riding off-road with a passenger.

Light off-road use does not include jumping the motorcycle or riding over obstacles. Do not attempt to jump over any bumps or obstacles. Do not attempt to ride over any obstacles.

Noise Control System

Tampering with the noise control system is prohibited.

Owners are warned that the law may prohibit:

1. The removal or rendering inoperative by any person other than for purposes of maintenance, repair or replacement, of any device or element of design incorporated into any new vehicle for the purpose of noise control prior to its sale or delivery to the ultimate purchaser or while it is in use and,
2. the use of the vehicle after such device or element of design has been removed or rendered inoperative by any person.

Among those acts presumed to constitute tampering are the acts listed below:

- ▼ Removal of, or puncturing the muffler, baffles, header pipes or any other component which conducts exhaust gases.
- ▼ Removal of or puncturing of any part of the intake system.
- ▼ Lack of proper maintenance.
- ▼ Replacing any moving parts of the vehicle, or parts of the exhaust or intake system, with parts other than those specified by the manufacturer.

Tiger 900 GT (LRH) Model

Unless stated otherwise, the information, instructions, and specifications for Tiger 900 GT (LRH) (Low Ride Height) models are identical to those detailed in this Owner's Handbook for the Tiger 900 GT standard ride height models.

The Motorcycle

Warning

Tiger 900 GT (LRH) (Low Ride Height Model)

The Tiger 900 GT (LRH) motorcycle is equipped with lowered suspension and has reduced ground clearance.

As a result, the cornering banking angles that can be achieved by the Tiger 900 GT (LRH) is reduced, when compared with the standard ride height Tiger 900 GT model.

When riding, it is important to remember that your motorcycle's ground clearance is limited. Operate your motorcycle in an area free from traffic to gain familiarity with the motorcycle's ground clearance and bank angle limitations.

Banking to an unsafe angle or unexpected contact with the ground may cause instability, loss of motorcycle control and an accident.

Warning

The motorcycles are designed for on-road and light off-road use. Light off-road use includes use on unpaved, dirt or gravel roads, but does not include riding on any motocross course, any off-road competition (such as motocross or enduro riding), or riding off-road with a passenger.

Light off-road use does not include jumping the motorcycle or riding over obstacles. Do not attempt to jump over any bumps or obstacles. Do not attempt to ride over any obstacles.

Extreme off-road use could lead to loss of motorcycle control and an accident.

Warning

This motorcycle is designed for use as a two-wheeled vehicle capable of carrying a rider on their own, or a rider and one passenger.

The total weight of the rider, and any passenger, accessories and luggage must not exceed the maximum load limit as stated in the Specifications section.

Warning

This motorcycle is not designed to tow a trailer or be equipped with a sidecar.

Installing a sidecar and/or a trailer may result in loss of control and an accident.

SAFETY FIRST

Warning

This motorcycle is equipped with a catalytic converter below the engine, which along with the exhaust system reaches a very high temperature during engine operation.

Flammable materials such as grass, hay/straw, leaves, clothing and luggage etc. could ignite if allowed to come into contact with any part of the exhaust system and catalytic converter.

Always make sure flammable materials are not allowed to contact the exhaust system or catalytic converter.

Warning

Riding the motorcycle off-road may result in loosening of the spokes.

Make sure that the spokes are checked before and after riding the motorcycle off-road. Tighten any loose spokes and check for wheel rim damage.

Spokes that are loose may affect handling and stability resulting in motorcycle damage, loss of motorcycle control and an accident.

Warning

Check the wheel rims and spokes regularly for wear and damage.

Check spoke tension at all intervals listed in the maintenance schedule. Tighten any loose spokes.

Incorrectly tightened spokes may affect handling and stability resulting in motorcycle damage, loss of motorcycle control and an accident.

Caution

Riding the motorcycle in extreme conditions such as wet and muddy roads, on rough terrain or in dusty and humid environments, may lead to above average wear and damage of certain components.

Therefore the servicing and replacement of worn or damaged components may be necessary before the scheduled maintenance service is reached.

It is important that the motorcycle is inspected after riding in extreme conditions and any worn or damaged components are serviced or replaced.

Fuel and Exhaust Fumes

Warning

GASOLINE IS HIGHLY FLAMMABLE:

Always turn off the engine when refueling.

Do not refuel or open the fuel filler cap while smoking or in the vicinity of any open (naked) flame.

Take care not to spill any gasoline on the engine, exhaust pipes or mufflers when refueling.

If gasoline is swallowed, inhaled or allowed to get into the eyes, seek immediate medical attention.

Spillage on the skin should be immediately washed off with soap and water and clothing contaminated with gasoline should immediately be removed.

Burns and other serious skin conditions may result from contact with gasoline.

Warning

Never start the engine or run the engine in a confined area.

Exhaust fumes are poisonous and can cause loss of consciousness and death within a short period of time.

Always operate the motorcycle in the open air or in an area with adequate ventilation.

Helmet and Clothing



Warning

When riding the motorcycle, both rider and passenger (on models where carrying a passenger is permitted) must always wear appropriate clothing including a motorcycle helmet, eye protection, gloves, boots, trousers (close fitting around the knee and ankle) and a brightly colored jacket.

During off-road use (on models suitable for off-road use), the rider must always wear appropriate clothing including trousers and boots.

Brightly colored clothing will considerably increase a rider's (or passenger's) visibility to other operators of road vehicles.

Although full protection is not possible, wearing correct protective clothing can reduce the risk of injury when riding.

SAFETY FIRST

Warning

A helmet is one of the most important pieces of riding gear as it offers protection against head injuries. You and your passenger's helmet should be carefully chosen and should fit you or your passenger's head comfortably and securely. A brightly colored helmet will increase a rider's (or passenger's) visibility to other operators of road vehicles.

An open face helmet offers some protection in an accident though a full face helmet will offer more.

Always wear a visor or approved goggles to help vision and to protect your eyes.

When choosing a helmet, always look for a DOT (Department of Transport) sticker indicating that the helmet has DOT approval. Do not buy a helmet without DOT approval.

Riding

Warning

Never ride the motorcycle when fatigued or under the influence of alcohol or other drugs.

Riding when under the influence of alcohol or other drugs is illegal.

Riding when fatigued or under the influence of alcohol or other drugs reduces the rider's ability to maintain control of the motorcycle and may lead to loss of control and an accident.

Warning

All riders must be licensed to operate the motorcycle.

Operation of the motorcycle without a license is illegal and could lead to prosecution.

Operation of the motorcycle without formal training in the correct riding techniques that are necessary to become licensed is dangerous and may lead to loss of motorcycle control and an accident.

Warning

Always ride defensively and wear the protective equipment mentioned elsewhere in this foreword.

Remember, in an accident, a motorcycle does not give the same impact protection as a car.

 **Warning**

This Triumph motorcycle should be operated within the legal speed limits for the particular road traveled.

Operating a motorcycle at high speeds can be potentially dangerous since the time available to react to given traffic situations is greatly reduced as road speed increases.

Always reduce speed in potentially hazardous driving conditions such as bad weather or heavy traffic.

 **Warning**

Continually observe and react to changes in road surface, traffic and wind conditions. All two-wheeled vehicles are subject to external forces which may cause an accident. These forces include but are not limited to:

- Wind draft from passing vehicles
- Potholes, uneven or damaged road surfaces
- Bad weather
- Rider error.

Always operate the motorcycle at moderate speed and away from heavy traffic until you have become thoroughly familiar with its handling and operating characteristics. Never exceed the legal speed limit.

Wobble/Weave

A weave is a relatively slow oscillation of the rear of the motorcycle, while a wobble is a rapid, possibly strong shaking of the handlebar. These are related but distinct stability problems usually caused by excessive weight in the wrong place, or by a mechanical problem such as worn or loose bearings or under-inflated or unevenly worn tires.

Your solution to both situations is the same. Keep a firm hold on the handlebars without locking arms or fighting the steering. Smoothly ease off the throttle to slow gradually. Do not apply the brakes, and do not accelerate to try to stop the wobble or weave. In some cases, it helps to shift your body weight forward by leaning over the tank.

Copyright © 2005 Motorcycle Safety Foundation. All rights reserved. Used with permission.

SAFETY FIRST

Handlebars and Footrests

Warning

The rider must maintain control of the motorcycle by keeping hands on the handlebars at all times.

The handling and stability of a motorcycle will be adversely affected if the rider removes their hands from the handlebars, resulting in loss of motorcycle control and an accident.

Warning

The rider and passenger (if applicable) must always use the footrests provided, during operation of the motorcycle.

By using the footrests, both rider and passenger will reduce the risk of inadvertent contact with any motorcycle components and will also reduce the risk of injury from entrapment of clothing.

Warning

The bank angle indicators must not be used as a guide to how far the motorcycle may be safely banked.

This depends on many various conditions including, but not limited to, road surface, tire condition and weather.

Banking to an unsafe angle may cause instability, loss of motorcycle control and an accident.

Warning

Always replace the bank angle indicators before they are worn to their maximum limit.

Use of a motorcycle with bank angle indicators worn beyond the maximum limit will allow the motorcycle to be banked to an unsafe angle.

Banking to an unsafe angle may cause instability, loss of motorcycle control and an accident.

Warning

When banking and the bank angle indicator, attached to the rider's footrest, makes contact with the ground, the motorcycle is nearing its bank angle limit. A further increase of the banking angle is unsafe.

Banking to an unsafe angle may cause instability, loss of motorcycle control and an accident.

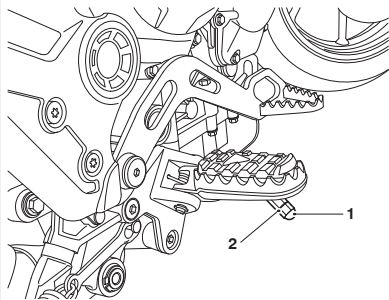

1. Bank angle indicator
2. Maximum wear limit groove

Parking

Warning

Always switch off the engine and remove the ignition key before leaving the motorcycle unattended. By removing the key, the risk of use of the motorcycle by unauthorized or untrained persons is reduced.

When parking the motorcycle, always remember the following:

- Engage first gear to help prevent the motorcycle from rolling off the stand.
- The engine and exhaust system will be hot after riding. DO NOT park where pedestrians, animals and/or children are likely to touch the motorcycle.
- Do not park on soft ground or on a steeply inclined surface. Parking under these conditions may cause the motorcycle to fall over.

For further details, please refer to the 'How to Ride the Motorcycle' section of this Owner's Handbook.

Parts and Accessories

Warning

Owners should be aware that the only approved parts, accessories and conversions for any Triumph motorcycle are those which carry official Triumph approval and are installed to the motorcycle by an authorized dealer.

In particular, it is extremely hazardous to install or replace parts or accessories whose installation requires the dismantling of, or addition to, either the electrical or fuel systems and any such modification could cause a safety hazard.

The installation of any non-approved parts, accessories or conversions may adversely affect the handling, stability or other aspect of the motorcycle operation that may result in an accident causing injury or death.

Triumph does not accept any liability whatsoever for defects caused by the installation of non-approved parts, accessories or conversions or the installation of any approved parts, accessories or conversions by non-approved personnel.

SAFETY FIRST

Maintenance and Equipment

Warning

Consult your authorized Triumph dealer whenever there is doubt as to the correct or safe operation of this Triumph motorcycle.

Remember that continued operation of an incorrectly performing motorcycle may aggravate a fault and may also compromise safety.

Warning

Make sure all equipment that is required by law is installed and functioning correctly.

The removal or alteration of the motorcycle's lights, mufflers, emission or noise control systems can violate the law.

Incorrect or improper modification may adversely affect the handling, stability or other aspect of the motorcycle operation, which may result in an accident causing injury or death.

Warning

If the motorcycle is involved in an accident, collision or fall, it must be taken to an authorized Triumph dealer for inspection and repair.

Any accident can cause damage to the motorcycle that, if not correctly repaired, may cause a second accident that may result in injury or death.

This page intentionally left blank

WARNING LABELS

Warning Label Locations

The labels detailed on this and the following pages draw your attention to important safety information in this handbook. Before riding, make sure that all riders have understood and complied with all the information to which these labels relate.

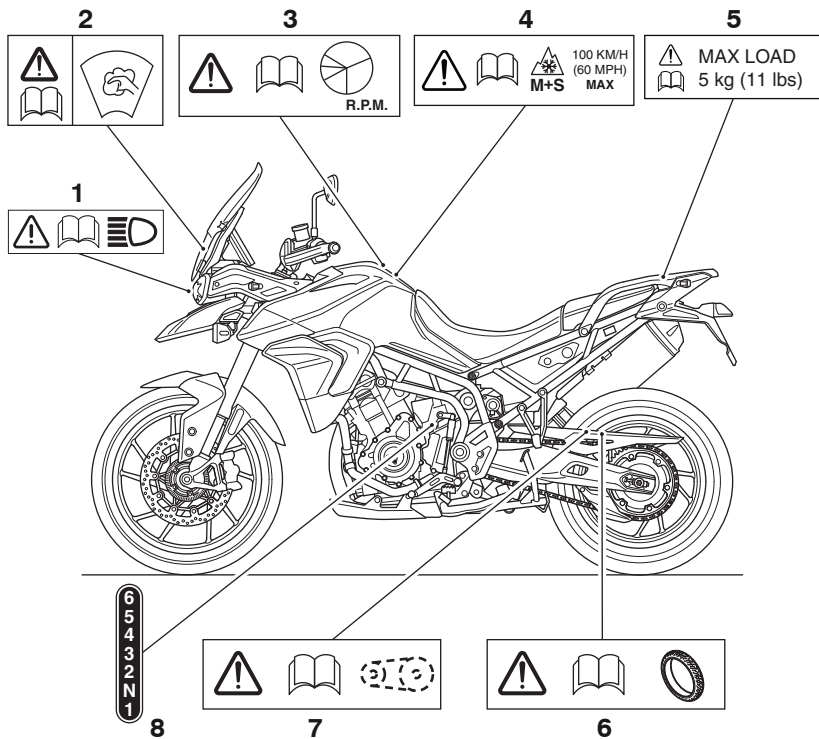

- | | |
|---|--------------------------------------|
| 1. Headlight (page 183) | 5. Panniers (if equipped) (page 123) |
| 2. Windshield (page 194) | 6. Tires (page 169) |
| 3. Breaking-In (page 107) | 7. Drive Chain (page 146) |
| 4. Mud and Snow Tires (page 214) (applies to certain option tires only) | 8. Gear Position (page 112) |

Warning Label Locations (continued)

⚠ Caution

All warning labels and decals, with the exception of the Breaking-in label, are mounted on the motorcycle using a strong adhesive. In some cases, labels are installed prior to an application of paint lacquer. Therefore, any attempt to remove the warning labels will cause damage to the paintwork or bodywork.

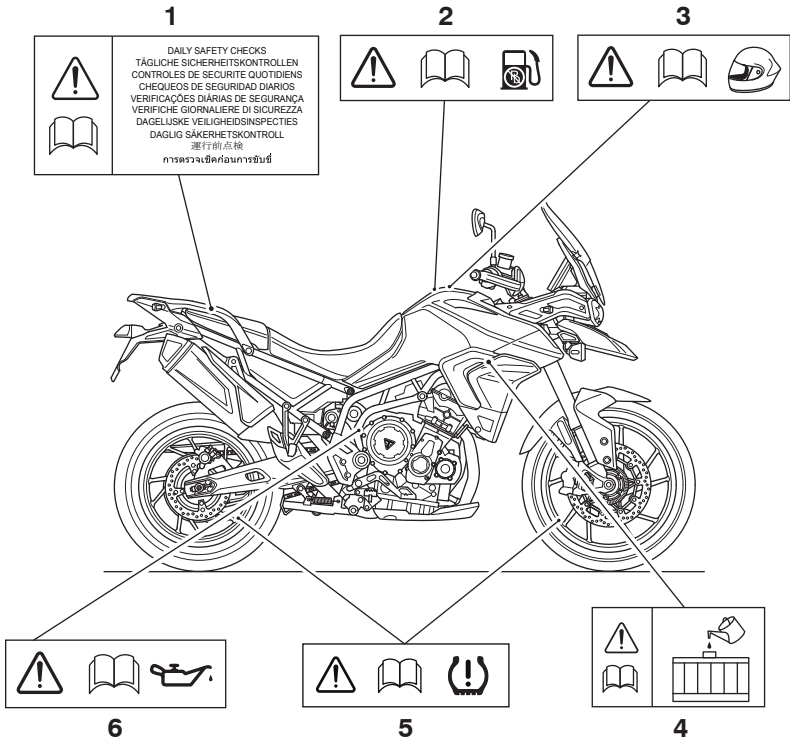

1. Daily Safety Checks (page 108)

2. Unleaded Fuel (page 90)

3. Helmet (page 09)

4. Coolant (page 141)

5. Tire Pressure Monitoring System (if equipped) (page 170)

6. Engine Oil (page 136)

Tiger 850 Sport, Tiger 900 GT and Tiger 900 GT Pro

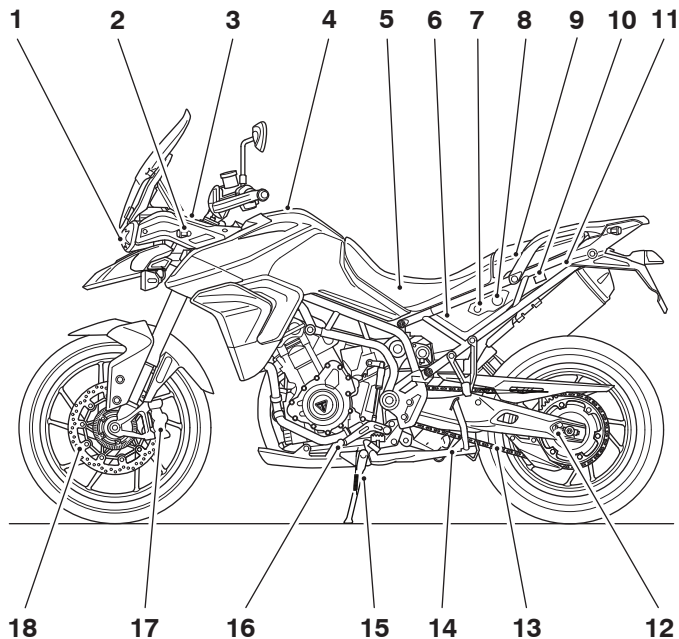

- | | |
|--|---|
| <ul style="list-style-type: none"> 1. Headlight 2. Front turn signal 3. Electrical accessory socket (front) 4. Fuel tank and fuel filler cap 5. Tool kit (under the rider seat on Tiger 900 GT and Tiger 900 GT Pro) 6. Battery and fuse boxes (under the rider seat) 7. Seat lock 8. Electrical accessory socket (rear if equipped) | <ul style="list-style-type: none"> 9. USB socket (under the passenger seat) (if equipped) 10. Heated rear seat switch (if equipped) 11. Tool kit (under the passenger seat on Tiger 850 Sport only) 12. Rear wheel adjuster 13. Drive chain 14. Center stand (if equipped) 15. Side stand 16. Gear shift pedal 17. Front brake caliper 18. Front brake disc |
|--|---|

Parts Identification - Continued

Tiger 850 Sport, Tiger 900 GT and Tiger 900 GT Pro

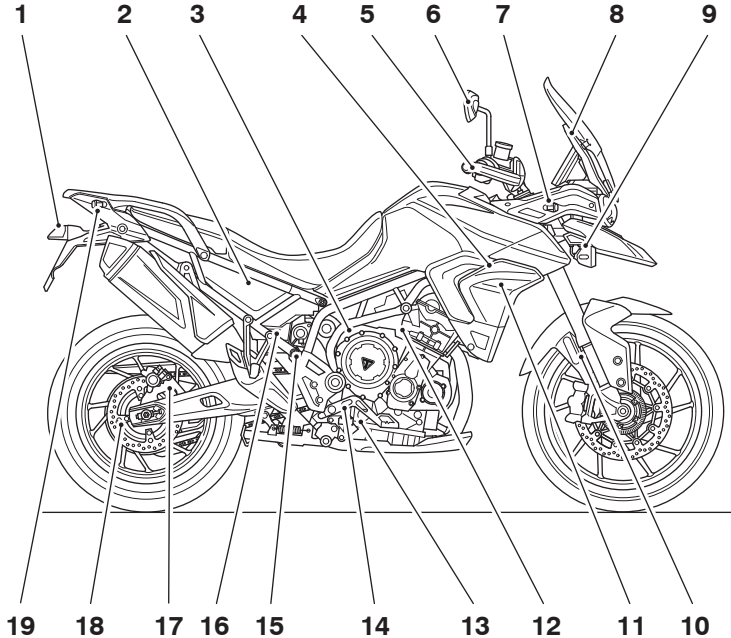

- | | |
|-----------------------------------|---|
| 1. Brake/tail light | 11. Radiator/Coolant pressure cap |
| 2. Bluetooth module (if equipped) | 12. Clutch cable |
| 3. Oil filler cap | 13. Engine oil level sight glass |
| 4. Coolant expansion tank | 14. Rear brake pedal |
| 5. Handguards (if equipped) | 15. Rear suspension spring preload adjuster |
| 6. Mirror | 16. Rear brake fluid reservoir |
| 7. Headlight adjuster | 17. Rear brake caliper |
| 8. Windshield | 18. Rear brake disc |
| 9. Fog light (if equipped) | 19. Rear turn signal |
| 10. Front fork | |

Parts Identification

Tiger 900 Rally, Tiger 900 Rally Pro and Tiger 900 Bond Edition

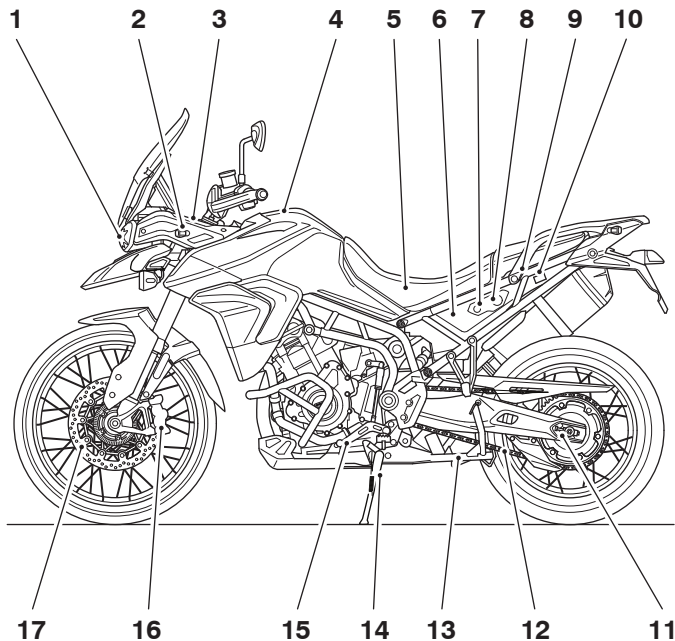

- | | |
|---|---|
| 1. Headlight | 9. USB socket (under the passenger seat) |
| 2. Front turn signal | 10. Heated rear seat switch (if equipped) |
| 3. Electrical accessory socket (front) | 11. Rear wheel adjuster |
| 4. Fuel tank and fuel filler cap | 12. Drive chain |
| 5. Tool kit (under the rider seat) | 13. Center stand (if equipped) |
| 6. Battery and fuse boxes (under the rider seat) | 14. Side stand |
| 7. Seat lock | 15. Gear shift pedal |
| 8. Electrical accessory socket (rear if equipped) | 16. Front brake caliper |
| | 17. Front brake disc |

Parts Identification - Continued

Tiger 900 Rally, Tiger 900 Rally Pro and Tiger 900 Bond Edition

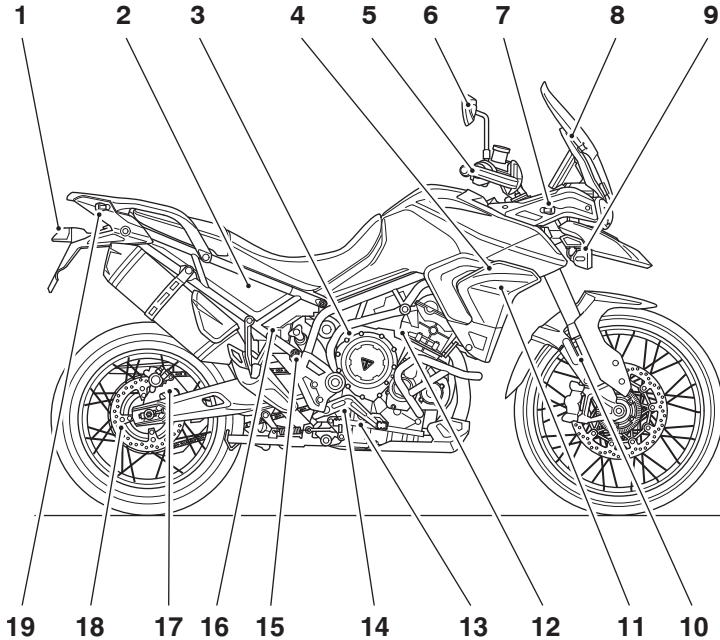

- | | |
|-----------------------------------|---|
| 1. Tail light | 11. Radiator/Coolant pressure cap |
| 2. Bluetooth module (if equipped) | 12. Clutch cable |
| 3. Oil filler cap | 13. Engine oil level sight glass |
| 4. Coolant expansion tank | 14. Rear brake pedal |
| 5. Handguards (if equipped) | 15. Rear suspension spring preload adjuster |
| 6. Mirror | 16. Rear brake fluid reservoir |
| 7. Headlight adjuster | 17. Rear brake caliper |
| 8. Windshield | 18. Rear brake disc |
| 9. Fog light (if equipped) | 19. Rear turn signal |
| 10. Front fork | |

Rider View Parts Identification

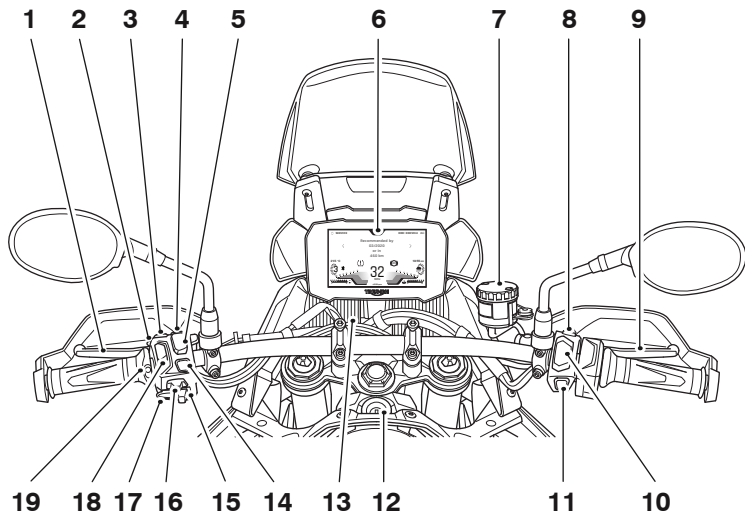

- | | |
|---|---|
| <ol style="list-style-type: none"> 1. Clutch lever 2. Headlight dimmer switch 3. Heated seats switch (if equipped) 4. Fog lights switch (if equipped) 5. Cruise control adjust switch 6. TFT instrument display 7. Front brake fluid reservoir 8. Hazard warning light button 9. Front brake lever 10. Engine start/stop button | <ol style="list-style-type: none"> 11. HOME button 12. Ignition switch 13. Electrical accessory socket 14. MODE button 15. Joystick button 16. Turn signal switch 17. Horn button 18. Daytime Running Lights (DRL) (if equipped) 19. Heated grips switch (if equipped) |
|---|---|

Vehicle Identification Number (VIN)

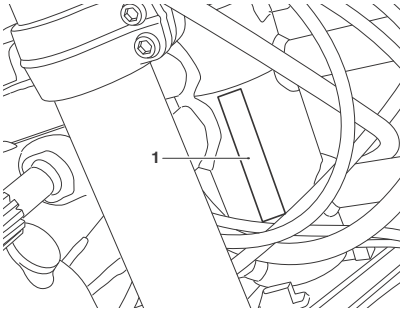

1. Vehicle identification number (right hand side)

The Vehicle Identification Number (VIN) is stamped into the steering head area of the frame. It is also displayed on a label attached to the left hand side of the steering head.

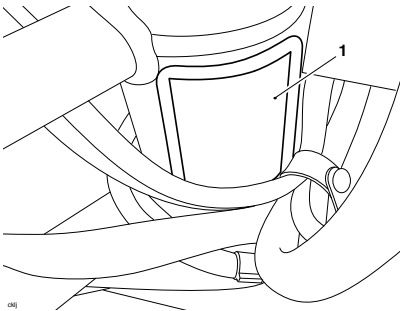

1. Vehicle identification label (left hand side)

Record the vehicle identification number in the space provided below.

Engine Serial Number

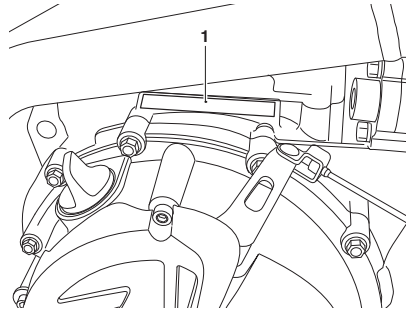

1. Engine serial number

The engine serial number is stamped on the engine crankcase, immediately above the clutch cover.

Record the engine serial number in the space provided below.

This page intentionally left blank

Table of Contents

Hand Controls	27
Ignition Switch/Steering Lock	27
Right Handlebar Switches	29
Left Handlebar Switches	31
Throttle Control	35
Brake Lever Adjuster	37
Clutch Lever Adjuster	38
Instruments	39
Instrument Displays Overview	39
Instrument Panel Layout	40
Display Styles	42
Warning Lights	42
Warning and Information Messages	49
Odometer and Speedometer	50
Tachometer	51
Fuel Gauge	51
Coolant Temperature Gauge	52
Ambient Air Temperature	53
Gear Position Display	54
Display Navigation	54
Riding Modes	55
Riding Mode Selection	56
Main Menu	58
Information Tray	72
Cruise Control	80
Activating Cruise Control	81
Adjusting the Set Speed While in Cruise Control	82
Deactivating Cruise Control	82
Resuming the Cruise Control Set Speed	83
Traction Control (TC)	84
Optimized Cornering Traction Control (if equipped)	85
Traction Control Settings	86
Tire Pressure Monitoring System (TPMS) (if equipped)	86
Tire Pressure Warning Light (if equipped with TPMS)	87
Tire Pressure Sensor Serial Number	88
Tire Pressures	88
Replacement Tires	89
Sensor Batteries	89

GENERAL INFORMATION

Fuel.....	90
Fuel Tank Cap.....	92
Filling the Fuel Tank.....	93
Stands.....	94
Center Stand (if equipped).....	95
Seats.....	96
Seat Care.....	96
Seat Lock.....	96
Passenger Seat.....	97
Rider's Seat.....	98
Rider's Seat Height Adjustment.....	99
Heated Seats (if equipped).....	100
Storage Compartment (if equipped).....	102
Windshield.....	103
Tool Kit.....	104
USB Socket (if equipped).....	105
Electrical Accessory Sockets.....	106
Breaking-In.....	107
Daily Safety Checks.....	108

Hand Controls

Ignition Switch/Steering Lock

Warning

For reasons of security and safety, always turn the ignition to the OFF or LOCK position and remove the key when leaving the motorcycle unattended.

Any unauthorized use of the motorcycle may cause injury to the user, other road users and pedestrians and may also cause damage to the motorcycle.

Warning

With the key in the LOCK position, the steering will become locked.

Never turn the key to the LOCK position while the motorcycle is moving as this will cause the steering to lock. Locked steering will cause loss of motorcycle control and an accident.

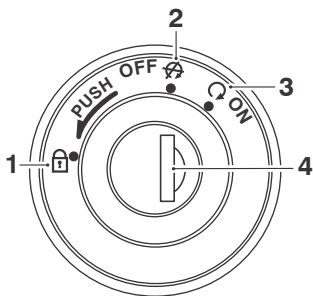

1. LOCK position
2. OFF position
3. ON position
4. Ignition switch/steering lock

Ignition Switch Positions

This is a three position, key operated switch. The key can be removed from the switch only when it is in the OFF or LOCK position.

To lock the motorcycle:

- ▼ Turn the handlebar fully to the left.
- ▼ Turn the key to the OFF position.
- ▼ Push and fully release the key.
- ▼ Rotate it to the LOCK position.

Engine Immobilizer

The ignition barrel housing acts as the antenna for the engine immobilizer. When the ignition switch is turned to the OFF position and the ignition key is removed, the engine immobilizer is active (see page 43). The engine immobilizer is deactivated when the ignition key is in the ignition switch and it is turned to the ON position.

Ignition Key

! Warning

Additional keys, key rings/chains or items attached to the ignition key may interfere with the steering, leading to loss of motorcycle control and an accident.

Remove all additional keys, key rings/chains and items from the ignition key before riding the motorcycle.

! Caution

Additional keys, key rings/chains or items attached to the ignition key may cause damage to the motorcycle's painted or polished components.

Remove all additional keys, key rings/chains and items from the ignition key before riding the motorcycle.

! Caution

Do not store the spare key with the motorcycle as this will reduce all aspects of security.

! Caution

Key functions may be disrupted by electronic devices, environmental electrical noise sources and metal objects.

Avoid storing and using the key near the following:

- Electrical service masts, radio masts and power distribution infrastructure
- Garage door opener devices
- Radio-Frequency IDentification (RFID) access cards or fobs
- Metal, metallic card holders and aluminum items
- Other vehicle electronic keys
- In panniers or top boxes
- Wireless communication devices such as mobile phones, tablets, laptops, portable game systems, audio players, radios and chargers.

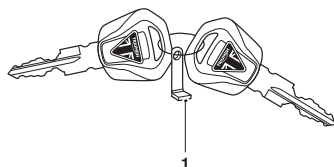
**1. Key number tag**

In addition to operating the ignition switch/steering lock, the ignition key is required to operate the seat lock and fuel tank cap.

When the motorcycle is delivered from the factory, two ignition keys are supplied together with a small tag bearing the key number. Make a note of the key number and store the spare key and key number tag in a safe place away from the motorcycle.

There is a transponder within the ignition keys to turn off the engine immobilizer. To make sure the immobilizer functions correctly, always have only one of the ignition keys near the ignition switch. Having two ignition keys near the switch may interrupt the signal between the transponder and the engine immobilizer. In this situation the engine immobilizer will remain active until one of the ignition keys is removed.

Always get replacement keys from your authorized Triumph dealer. Replacement keys must be 'paired' with the motorcycle's immobilizer by your authorized Triumph dealer.

Right Handlebar Switches

The switches are illuminated on Tiger 900 GT Pro and Tiger 900 Rally Pro.

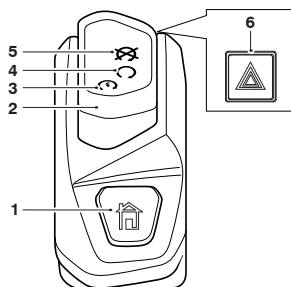

1. HOME button
2. Engine start/stop switch
3. START position
4. RUN position
5. STOP position
6. Hazard warning lights switch

The following sections describe the handlebar buttons and switches functions.

HOME Button

The HOME button is used to access the main menu on the instrument display.

Press and release the HOME button to select between the main menu and instrument display.

All messages that appear in the instrument display must be acknowledged by pressing the Joystick center before the HOME button can be operated.

GENERAL INFORMATION

Engine Stop Switch

In addition to the ignition switch being turned to the ON position, the engine stop switch must be in the RUN position for the motorcycle to operate.

The engine stop switch is for emergency use. If an emergency arises which requires the engine to be stopped, move the engine stop switch to the STOP position.

Note

Although the engine stop switch stops the engine, it does not turn off all the electrical circuits and may cause difficulty in restarting the engine due to a discharged battery. Ordinarily, only the ignition switch should be used to stop the engine.



Caution

Do not leave the ignition switch in the ON position unless the engine is running as this may cause damage to electrical components and will discharge the battery.

Starter Button

The starter button operates the electric starter. For the starter to operate, the clutch lever must be pulled to the handlebar.

Note

Even if the clutch lever is pulled to the handlebar, the starter will not operate if the side stand is down and a gear is engaged.

Hazard Warning Lights Button

To turn the hazard warning lights on or off, press and release the hazard warning light button.

The ignition must be switched on for the hazard warnings lights to be activated, but the hazard lights will remain active if the ignition is switched off until the hazard warning light button is pressed again.

Left Handlebar Switches

The switches are illuminated on Tiger 900 GT Pro and Tiger 900 Rally Pro.

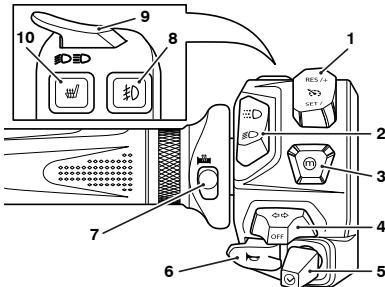

0407

1. Cruise control adjust switch (if equipped)
2. Daytime Running Lights (DRL) switch (if equipped)
3. MODE button
4. Turn signal switch
5. Joystick button
6. Horn button
7. Heated grips switch (if equipped)
8. Front fog lights switch (if equipped)
9. High beam button
10. Rider heated seat switch (if equipped)

The following sections describe the handlebar buttons and switches functions.

Cruise Control Adjust Switch

The cruise control adjust switch is a two way switch with the top marked RES/+ and the bottom marked SET/-.

For more information on cruise control operation, see page 80.

Daytime Running Lights (DRL) Switch (if equipped)



When the ignition is switched ON and the daytime running lights switch is set to DRL mode, the daytime running lights warning light will illuminate.

The daytime running lights and low beam headlights are operated manually using the DRL switch. Press the top of the switch for DRL mode, and the bottom of the switch for low beam headlight mode.

Warning

Do not ride for longer than necessary in poor ambient light conditions with the Daytime Running Lights (DRL) in use.

Riding with the daytime running lights when dark, in tunnels or where poor ambient light is apparent may reduce the riders vision or blind other road users.

Blinding other road users or reduced vision in low ambient light levels may result in loss of motorcycle control and an accident.

Note

During daylight hours the daytime running lights improve the motorcycles visibility to other road users.

Low beam headlights must be used in any other conditions unless the road conditions allow for high beam headlights to be used.

GENERAL INFORMATION

MODE Button

When the MODE button is pressed and released it will activate the Riding Mode Selection Menu in the display screen. Further presses of the MODE button will scroll through the available riding modes, see Riding Mode Selection on page 56.

Press and hold the MODE button when a riding mode is selected provides direct access to the riding mode's configuration menu.

For more information on riding mode selection and configuration, see page 60.

Turn Signal Switch

When the turn signal switch is pushed to the left or right and released, the corresponding turn signals will flash on and off. To turn off the turn signals, push and release the switch in the central position.

Automatic Self-Canceling Turn Signals

A short press and release of the turn signal switch to the left or right will cause the corresponding turn signals to flash on and off three times, then go off.

A longer press and release of the turn signal switch to the left or right will cause the corresponding turn signals to flash on and off.

The turn signals are automatically turned off after eight seconds and after riding a further 71 yards (65 meters).

To disable the turn signal self-cancel system refer to the Bike Setup section on page 63.

The turn signals can be canceled manually. To manually turn off the turn signal, press and release the turn signal switch in the central position.

Joystick Button

The Joystick is used to operate the following functions of the instruments:

- ▼ Up - scroll the menu from the bottom to the top
- ▼ Down - scroll the menu from the top to the bottom
- ▼ Left - scroll the menu to the left
- ▼ Right - scroll the menu to the right
- ▼ Center - press to confirm selection.

Horn Button

When the horn button is pushed, with the ignition switch turned to the ON position, the horn will sound.

Heated Grips Switch

The heated grips will only heat when the engine is running.

When the heated grips are switched on, the heated grips symbol will appear in the display and the selected heat level will be shown.

There are three levels of heat: low, medium and high. This is indicated by the different colors of the symbols shown in the display.

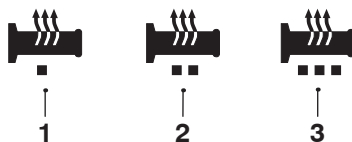

1. Low heat symbol (yellow)
2. Medium heat symbol (orange)
3. High heat symbol (red)

For maximum benefit in cold conditions, from the OFF position press the switch once for the high heat setting initially and then reduce the heat level by pressing the switch again for a low heat setting when the grips have warmed up.

To turn off the heated grips, press and release the switch until the heated grips symbol is no longer shown in the display.

Low Power Voltage Cut Off

If a low voltage is detected, the heated grips switch will power off. The heated grips will not function again until the voltage rises to a safe level.

The switch will not power back on automatically even if the voltage rises to the safe level. The user must manually press the switch again to activate the heated grips.

GENERAL INFORMATION

Fog Lights Switch (if equipped)

To turn the fog lights on or off, with the headlights on, press and release the fog lights switch. When the fog lights are turned on, the fog lights indicator will illuminate in the display.

The fog lights switch will only operate when the headlights are on. The fog lights switch will reset to off when the ignition is turned off then on again.

High Beam Button

The high beam button has a different function depending on whether Daytime Running Lights (DRL) are installed or not. When the high beam is turned on, the high beam indicator light will illuminate in the display.

Models with Daytime Running Lights (DRL)

If the DRL switch is in the Daytime Running Lights (DRL) position, then press and hold the high beam button to turn the high beam on. It will remain on as long as the button is held in and will turn off as soon as the button is released.

If the DRL switch is in the dip beam position, press the high beam button to switch the high beam on. Each press of the button will swap between dip and high beam.

A lighting on/off switch is not installed on this model. The brake/tail light and license plate light all function automatically when the ignition is turned to the ON position. The headlight will function when the ignition is turned on and the engine is running.

Models without Daytime Running Lights (DRL)

Press the high beam button to switch the high beam on. Each press of the button will swap between dip and high beam.

A lighting on/off switch is not installed on this model. The position light, brake/tail light and license plate light all function automatically when the ignition is turned to the ON position. The headlight will function when the ignition is turned on and the engine is running.

Rider Heated Seat Switch (if equipped)

The rider heated seat will only heat when the engine is running. When the heated seat is switched on the heated seats symbols will appear in the instrument display. The selected heat level will also be indicated by the color of the symbol. For more information, see page 100.

Throttle Control

This Triumph model has an electronic throttle twist grip to open and close the throttles via the engine control unit. There are no direct-acting cables in the system.

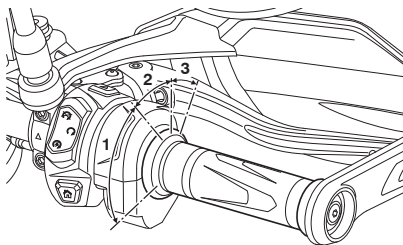

1. Throttle open position
2. Throttle closed position
3. Cruise control cancel position

The throttle grip has a resistive feel to it as it is rolled rearwards to open the throttles. When the grip is released it will return to the throttle closed position by its internal return spring and the throttles will close.

From the closed position, the throttle twist grip can be rolled forward 0.12 - 0.16 in (3 - 4 mm) to deactivate the cruise control (if equipped), see page 81.

There are no user adjustments for the throttle control.

GENERAL INFORMATION

If there is a malfunction with the throttle control the Malfunction Indicator Light (MIL) becomes illuminated and one of the following engine conditions may occur:

- ▼ MIL illuminated, restricted engine RPM and throttle movement
- ▼ MIL illuminated, limp-home mode with the engine at a fast idle condition only
- ▼ MIL illuminated, engine will not start.

For all of the above conditions contact an authorized Triumph dealer as soon as possible to have the fault checked and rectified.

Warning

Reduce speed and do not continue to ride for longer than is necessary with the Malfunction Indicator Light (MIL) illuminated.

The fault may adversely affect engine performance, exhaust emissions and fuel consumption.

Reduced engine performance could cause a dangerous riding condition, leading to loss of control and an accident. Contact an authorized Triumph dealer as soon as possible to have the fault checked and rectified.

Brake Use

At low throttle opening (approximately 20°), the brakes and throttle can be used together.

At high throttle opening (greater than 20°), if the brakes are applied for greater than two seconds the throttles will close and the engine speed will reduce. To return to normal throttle operation, release the throttle control, release the brakes and then reopen the throttle.

Brake Lever Adjuster

Warning

Do not attempt to adjust the levers with the motorcycle in motion as this may lead to loss of motorcycle control and an accident.

After adjusting the levers, operate the motorcycle in an area free from traffic to gain familiarity with the new lever setting.

Do not loan your motorcycle to anyone as they may change the lever setting from the one you are familiar with causing loss of motorcycle control and an accident.

An adjuster is mounted to the front brake lever. The adjuster allows the distance from the handlebar to the brake lever to be changed to suit the span of the rider's hands.

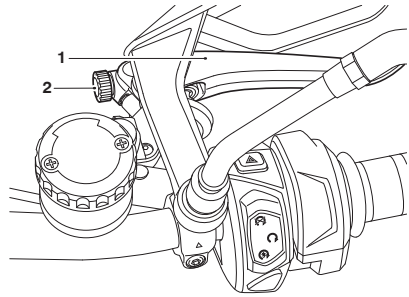

1. Brake lever
2. Adjuster wheel

To adjust the brake lever:

- ▼ Rotate the adjuster wheel to the required position.
- ▼ The distance from the handlebar grip to the released lever is shortest when the adjuster wheel is turned fully counterclockwise. It is the longest when the adjuster wheel is turned fully clockwise.

Clutch Lever Adjuster

Warning

Do not attempt to adjust the levers with the motorcycle in motion as this may lead to loss of motorcycle control and an accident.

After adjusting the levers, operate the motorcycle in an area free from traffic to gain familiarity with the new lever setting.

Do not loan your motorcycle to anyone as they may change the lever setting from the one you are familiar with causing loss of motorcycle control and an accident.

An adjuster is mounted to the clutch lever. The adjuster allows the distance from the handlebar to the clutch lever to be changed to one of four positions to suit the span of the rider's hands.

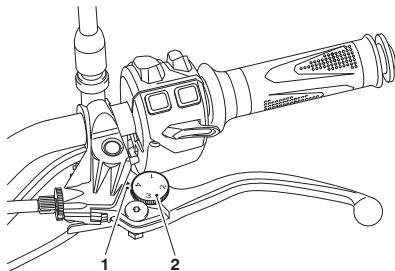

1. **Arrow mark**
2. **Adjuster wheel (handguard removed for clarity)**

To adjust the clutch lever:

- ▼ Push the clutch lever forward and turn the adjuster wheel to align one of the numbered positions with the arrow mark on the lever holder.
- ▼ The distance from the handlebar grip to the released clutch lever is shortest when set to number four, and longest when set to number one.

GENERAL INFORMATION

Instruments

Instrument Displays Overview

Tiger 850 Sport models are equipped with a full color Thin Film Transistor (TFT) digital instrument display with a 5 inch (12.7 cm) screen.

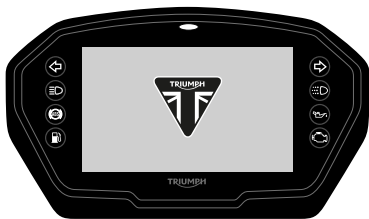

TFT Instrument Display - 5 inch (12.7 cm) Screen

All models except Tiger 850 Sport are equipped with a full color Thin Film Transistor (TFT) digital instrument display with a 7 inch (17.8 cm) screen.



TFT Instrument Display - 7 inch (17.8 cm) Screen

Not all instrument features are available on all models.

GENERAL INFORMATION

Instrument Panel Layout

Tiger 850 Sport models are equipped with a full color Thin Film Transistor (TFT) instrument display with a 5 inch (12.7 cm) screen.

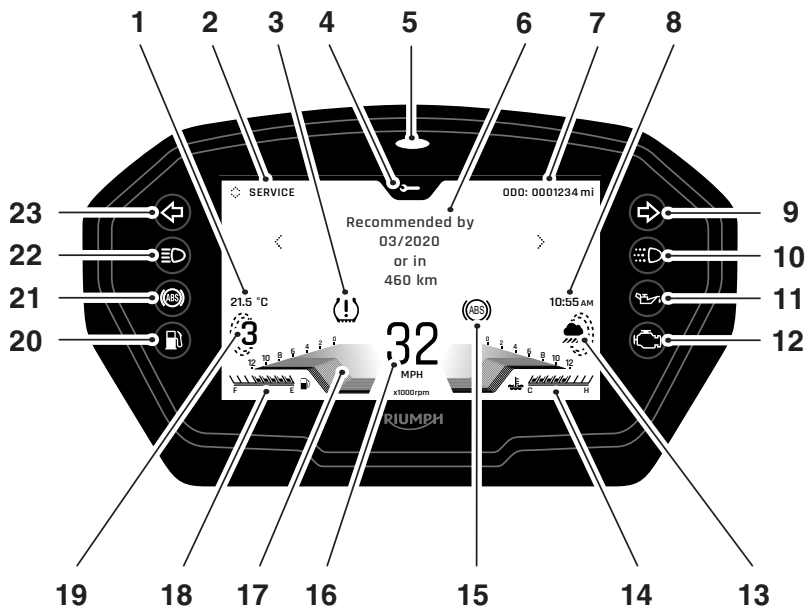

1. Ambient air temperature
2. Information tray title
3. Warning light location - TPMS warning light shown
4. Information tray icon
5. Alarm/immobilizer status indicator light (alarm is an accessory kit)
6. Information tray area
7. Odometer
8. Clock
9. Right hand turn signal and hazard warning light
10. Daytime Running Light (DRL) (if equipped)
11. Oil pressure warning light
12. Engine management Malfunction Indicator Light (MIL)
13. Current riding mode
14. Coolant temperature gage
15. Warning light location - ABS warning light shown
16. Speedometer
17. Tachometer
18. Fuel gage
19. Gear position
20. Fuel level low warning light
21. ABS warning light
22. High beam warning light
23. Left hand turn signal and hazard warning light

All models except Tiger 850 Sport are equipped with a full color Thin Film Transistor (TFT) digital instrument display with a 7 inch (17.8 cm) screen.

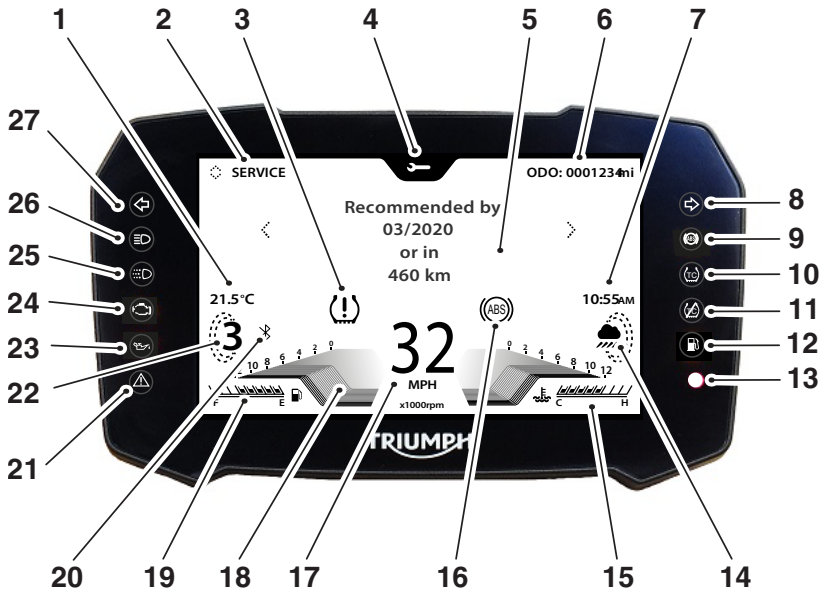

- | | |
|--|---|
| 1. Ambient air temperature | 15. Coolant temperature gage |
| 2. Information tray title | 16. Warning light location - ABS warning light shown |
| 3. Warning light location - TPMS warning light shown | 17. Speedometer |
| 4. Information tray icon | 18. Tachometer |
| 5. Information tray area | 19. Fuel gage |
| 6. Odometer | 20. Bluetooth® |
| 7. Clock | 21. Hazard warning light |
| 8. Right hand turn signal light | 22. Gear position |
| 9. ABS warning light | 23. Oil pressure warning light |
| 10. Traction control warning light | 24. Engine management Malfunction Indicator Light (MIL) |
| 11. Traction control OFF warning light | 25. Daytime Running Light (DRL) (if equipped) |
| 12. Fuel level low warning light | 26. High beam warning light |
| 13. Alarm/immobilizer status indicator light (alarm is an accessory kit) | 27. Left hand turn signal light |
| 14. Current riding mode | |

GENERAL INFORMATION

Display Styles

There are four different display styles to select from.

Style 03 is used for visual recognition and consistency throughout this owner's handbook.

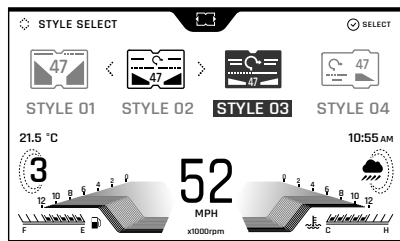

To select a style, see page 78 for more information.

Warning Lights

Caution

If a red warning light is shown then the motorcycle must be stopped immediately. Read any warning messages and rectify the issue.

If an amber warning light is shown then the motorcycle does not need to be stopped immediately. Read any warning messages and rectify the issue.

When the ignition is switched on, the instrument warning lights will illuminate for 1.5 seconds and will then go off (except those which remain on until the engine starts, as described in the following pages).

For additional warning and information messages, see page 49.

Engine Management System Malfunction Indicator Light (MIL)



The Malfunction Indicator Light (MIL) for the engine management system illuminates when the ignition is switched ON (to indicate that it is working) but should not become illuminated when the engine is running.

If the engine is running and there is a fault with the engine management system the MIL will be illuminated and the general warning symbol will flash. In such circumstances, the engine management system may switch to 'limp-home' mode so that the journey may be completed, if the fault is not so severe that the engine will not run.

Warning

Reduce speed and do not continue to ride for longer than is necessary with the MIL illuminated. The fault may adversely affect engine performance, exhaust emissions and fuel consumption.

Reduced engine performance could cause a dangerous riding condition, leading to loss of control and an accident.

Contact an authorized Triumph dealer as soon as possible to have the fault checked and rectified.

Note

If the MIL flashes when the ignition is switched ON contact an authorized Triumph dealer as soon as possible to have the situation rectified. In these circumstances the engine will not start.

Low Oil Pressure Warning Light



With the engine running, if the engine oil pressure becomes dangerously low, the low oil pressure warning light will illuminate. The low oil pressure warning light will also illuminate if the ignition is switched ON without running the engine.

Caution

Stop the engine immediately if the low oil pressure warning light illuminates. Do not restart the engine until the fault has been rectified.

Severe engine damage will result from running the engine when the low oil pressure warning light is illuminated.

Immobilizer/Alarm Indicator Light

This Triumph motorcycle is equipped with an engine immobilizer which is activated when the ignition switch is turned to the OFF position.

Without Alarm Equipped

When the ignition switch is turned to the OFF position, the immobilizer light will flash on and off for 24 hours to show that the engine immobilizer is on. When the ignition switch is turned to the ON position the immobilizer and the indicator light will be off.

If the indicator light remains on it indicates that the immobilizer has a malfunction that requires investigation. Contact an authorized Triumph dealer as soon as possible to have the fault checked and rectified.

With Alarm Equipped

The immobilizer/alarm light will only illuminate when the conditions described in the genuine Triumph accessory alarm instructions are met.

GENERAL INFORMATION

Anti-lock Braking System (ABS) Warning Light



When the ignition is switched on, it is normal that the ABS warning light will flash on and off. The light will continue to flash after engine start-up until the motorcycle first reaches a speed exceeding 6 mph (10 km/h) when it will go off.

Traction control will not function if there is a malfunction with the ABS. The warning lights for the ABS, traction control and the MIL will be illuminated.

If the ABS warning light is constantly illuminated it indicates that the ABS function is not available because:

- ▼ The ABS has been disabled by the rider.
- ▼ The ABS has a malfunction that requires investigation.

If the indicator light becomes illuminated while riding, it indicates that the ABS has a malfunction that requires investigation.

Optimized Cornering ABS (OCABS) (if equipped)

The warning light will flash slowly if Optimized Cornering ABS (OCABS) is switched off by the OFF-ROAD or OFF-ROAD PRO riding modes. A warning message will be shown in the instrument display.

If the warning light becomes illuminated at any other time while riding it indicates that the ABS has a malfunction that requires investigation.



Warning

If the ABS is not functioning, the brake system will continue to function as a non-ABS equipped brake system.

Do not continue to ride for longer than is necessary with the warning light illuminated.

Contact an authorized Triumph dealer as soon as possible to have the fault checked and rectified. In this situation braking too hard will cause the wheels to lock resulting in loss of motorcycle control and an accident.

Traction Control (TC) Indicator Light



The Traction Control (TC) indicator light is used to indicate that the traction control system is active and is working to limit rear wheel slip during periods of hard acceleration or under wet or slippery road conditions. Traction control will not function if there is a malfunction with the ABS. The warning lights for the ABS, traction control and the MIL will be illuminated.

Warning

If the traction control is not functioning, care must be taken when accelerating and cornering on wet/slippery road surfaces to avoid rear wheel spin.

Do not continue to ride for longer than is necessary with the engine management system Malfunction Indicator Light (MIL) and traction control warning lights illuminated. Contact an authorized Triumph dealer as soon as possible to have the fault checked.

Hard acceleration and cornering in this situation may cause the rear wheel to spin resulting in loss of motorcycle control and an accident.

If traction control is switched on:

- ▼ Under normal riding conditions the TC indicator light will remain off.
- ▼ The TC indicator light will flash rapidly when the traction control system is working to limit rear wheel slip during periods of hard acceleration or under wet or slippery road conditions.

If traction control is switched off:

- ▼ The TC indicator light will not illuminate. Instead the TC disabled warning light will be illuminated.

Traction Control (TC) Disabled Warning Light



The TC disabled warning light should not illuminate unless traction control is switched off or there is a malfunction.

If the warning light becomes illuminated while riding, it indicates that the traction control system has a malfunction that requires investigation.

GENERAL INFORMATION

Turn Signals



When the turn signal switch is turned to the left or right, the indicator warning light will flash on and off at the same speed as the turn signals.

Hazard Warning Lights

To turn the hazard warning lights on or off, press and release the hazard warning light switch.

The ignition must be switched ON for the hazard warning lights to function.

The hazard warning lights will remain on if the ignition is switched OFF, until the hazard warning light switch is pressed again.

High Beam Light



When the high beam button is pressed the high beam will be switched on. Each press of the button will swap between dip and high beam.

If daytime running lights are installed on the motorcycle, the high beam button has additional functionality.

If the DRL switch is in the daytime running lights position, then press and hold the high beam button to turn the high beam on. It will remain on as long as the button is held in and will turn off as soon as the button is released.

A lighting on/off switch is not installed on this model. The tail light and license plate light all function automatically when the ignition is on.

The headlight will function when the ignition is on. The headlight will go off while pressing the starter button until the engine starts.

Daytime Running Lights (DRL) (if equipped)



When the ignition is switched ON and the daytime running lights switch is set to Daytime Running Lights, the daytime running lights warning light will illuminate. During daylight hours, the Daytime Running Lights (DRL) improve the visibility of the motorcycle to other road users. Low beam headlights must be used in any other conditions unless the road conditions allow for high beam headlights to be used.

The daytime running lights and low beam headlights are operated manually using a switch on the left hand switch housing, see page 47.

Low Fuel Warning Light



The low fuel warning light will illuminate when there are approximately 0.92 gallons (3.5 liters) of fuel remaining in the tank.

Warning

Do not ride for longer than necessary in poor ambient light conditions with the Daytime Running Lights (DRL) in use.

Riding with the Daytime Running Lights when dark, in tunnels or where poor ambient light is apparent may reduce the riders vision or blind other road users.

Blinding other road users or reduced vision in low ambient light levels may result in loss of motorcycle control and an accident.

GENERAL INFORMATION

Tire Pressure Warning Light (if equipped with TPMS)

Warning

Stop the motorcycle if the tire pressure warning light illuminates.

Do not ride the motorcycle until the tires have been checked and the tire pressures are at their recommended pressure when cold.

Note

The **Tire Pressure Monitoring System (TPMS)** is installed on some models and is available as an accessory for models without TPMS.



The tire pressure warning light works with the Tire Pressure Monitoring System (TPMS), see page 86.

The warning light will only illuminate when the front or rear tire pressure is below the recommended pressure. It will not illuminate if the tire is over inflated.

When the warning light is illuminated, the TPMS symbol indicating which is the deflated tire and its pressure will automatically be shown in the display area.

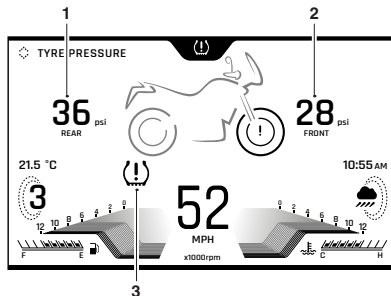

1. Rear tire indicator
2. Front tire indicator
3. Tire pressure warning light







The tire pressure at which the warning light illuminates is temperature compensated to 68°F (20°C) but the numeric pressure display associated with it is not, see page 170. Even if the numeric display seems at or close to the standard tire pressure when the warning light is on, a low tire pressure is indicated and a puncture is the most likely cause.



The tire pressure warning light also illuminates to indicate a low sensor battery or loss of signal.

Warning and Information Messages

It is possible for multiple warning and information messages to be shown when a fault occurs. Where this is the case, warning messages will take priority over information messages and the warning symbol will be shown on the display. The number of currently active warning messages is shown in the information tray.

The following warning and information messages may be shown if a fault is detected on the motorcycle.

	LOW OIL PRESSURE - CHECK MANUAL (red indicator)
	CHECK ENGINE (amber indicator)
	ABS SYSTEM DISABLED - CHECK MANUAL (amber indicator)
	BATTERY LOW - CHECK MANUAL (red indicator)
	SENSOR SIGNAL FRONT/REAR TIRE - CHECK MANUAL (red indicator)
	BATTERY LOW FRONT/REAR TIRE - CHECK MANUAL (amber indicator)
	TC-SYSTEM DISABLED - CHECK MANUAL (amber indicator)

	SERVICE OVERDUE - CONTACT DEALER (amber indicator)
	BULB FAULT LEFT/RIGHT FRONT/REAR TURN SIGNAL - CHECK MANUAL (amber indicator)
	CAUTION: LOW AIR TEMPERATURE - RISK OF SURFACE ICE

If more than one message is displayed then the left/right arrow becomes active, push the joystick left/right to show other messages.

Press the joystick center to acknowledge and hide each message.

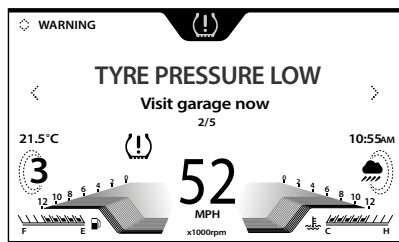

Tire Pressure Low Warning Shown

Push the joystick left or right to review the warnings previously acknowledged.

When a warning or information message is activated, the message will be accompanied by the relevant warning or information symbol in the instrument panel.

Warning and information messages will be shown until they have been rectified.

GENERAL INFORMATION

Warning Message when Ignition Switch is Turned ON

To view the warning messages in styles 01, 02 and 03, push the joystick left/right. To view the information trays in styles 04, push the joystick down/up.

If a warning message has been acknowledged but not rectified, the message will appear again when the ignition switch is turned to the ON position.

The arrow to access to the information trays are inactive and it is not possible to change the information tray until the warning message has been acknowledged or rectified.

If more than one message is displayed then the left/right arrow becomes active, push the joystick left/right to show other messages.

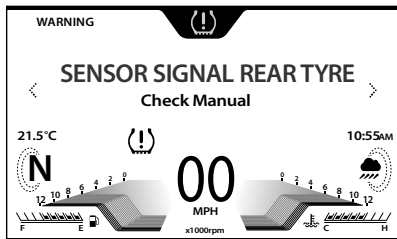

Sensor Signal Warning Shown

Odometer and Speedometer

The odometer shows the total distance that the motorcycle has traveled. The odometer is only shown in the Service information tray.

The speedometer indicates the road speed of the motorcycle.

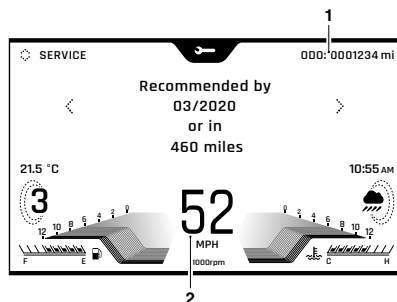

1. Odometer
2. Speedometer

Tachometer

The tachometer shows the engine speed in revolutions per minute - rpm (r/min). At the end of the tachometer range there is the red zone. Engine speeds in the red zone are above maximum recommended engine speed and are also above the range for best performance.

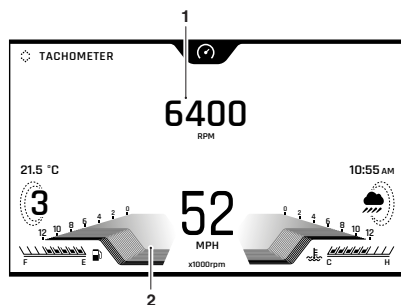

1. Engine speed (rpm) shown in a numerical format
2. Engine speed (rpm) shown in a graph format

Fuel Gauge

The fuel gage indicates the amount of fuel in the tank from F (full tank) to E (empty tank).

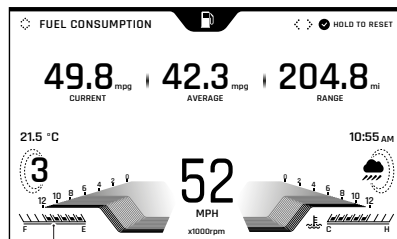

1. Fuel gage

With the ignition switched on, the fuel remaining in the fuel tank is indicated by the amount of gage segments that are shown full.

When the fuel tank is full, all gage segments are shown full. When the fuel tank is empty, all gage segments are shown empty. Other gage markings indicate intermediate fuel levels between full and empty.

The low fuel warning light will illuminate when approximately 0.92 gallons (3.5 liters) of fuel is remaining in the tank and the motorcycle should be refueled at the earliest opportunity. The range to empty and instantaneous fuel consumption will be also shown in the Information tray. Press the joystick center to acknowledge and hide the low fuel warning.

After refueling, the fuel gage and range to empty information will be updated only while riding the motorcycle. Depending on the riding style, updating could take up to five minutes.

GENERAL INFORMATION

Coolant Temperature Gauge

The coolant temperature gauge indicates the temperature of the engine coolant.

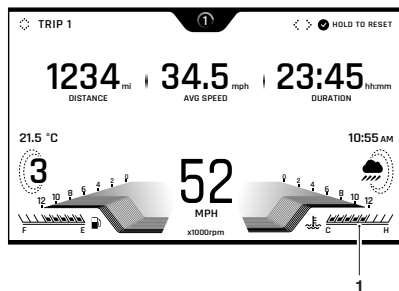

1. Coolant temperature gage

When the engine is started from cold, the coolant temperature gage will show empty gage segments. As the temperature increases more gage segments will be shown full. When the engine is started from hot, the coolant temperature gage will show the relevant number of full gage segments, dependent on engine temperature.

The normal temperature range is between the C (cold) and H (hot) on the coolant temperature gage.

With the engine running, if the engine coolant temperature becomes dangerously high, the high coolant temperature warning light will illuminate in the warning light location and the high coolant temperature warning information tray will be shown.

The arrow to access the information trays are inactive and it is not possible to change the information tray until the warning message has been acknowledged or rectified.

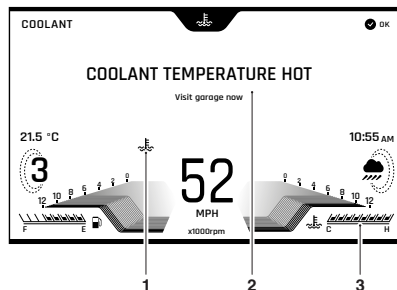

1. Coolant temperature warning light
2. Coolant warning information tray
3. Coolant temperature gage

Caution

Stop the engine immediately if the high coolant temperature warning light illuminates. Do not restart the engine until the fault has been rectified.

Severe engine damage will result from running the engine when the high coolant temperature warning light is illuminated.

Ambient Air Temperature

The ambient air temperature is displayed as either °C or °F.

When the motorcycle is stationary the heat of the engine may affect the accuracy of the ambient temperature display.

Once the motorcycle starts moving the display will return to normal after a short time.

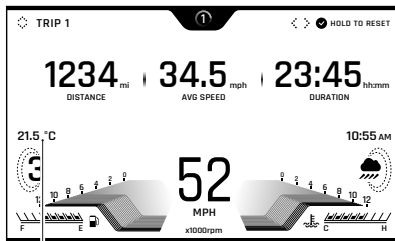

1

1. Ambient air temperature

To change the temperature from °C or °F, see page 69.

Frost Symbol

! Warning

Black ice (sometimes called clear ice) can form at temperatures several degrees above freezing, 32°F (0°C), especially on bridges and in shaded areas.

Always take extra care when the temperatures are low and reduce speed in potentially hazardous driving conditions such as bad weather.

Excess speed, hard acceleration, heavy braking or hard cornering when roads are slippery may result in loss of motorcycle control and an accident.



The frost symbol will illuminate if the ambient air temperature is 39°F (4°C) or lower.

The frost symbol will remain illuminated until the temperature rises to 42°F (6°C).

A message will also be shown in the information tray.

GENERAL INFORMATION

Gear Position Display

The gear position display indicates which gear (one to six) has been engaged. When the transmission is in neutral (no gear selected), the display will show N.

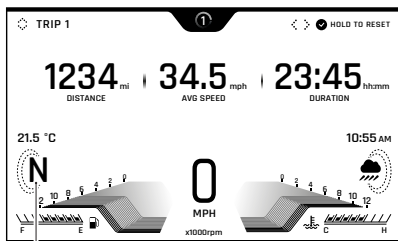

1

1. Gear position display (neutral position displayed)

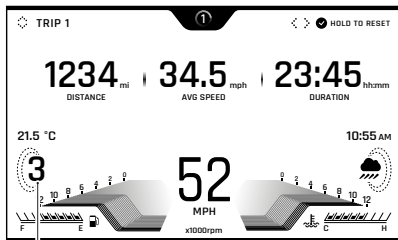











1

1. Gear position display (third gear displayed)

Display Navigation

The table below describes the instrument icons and buttons used to navigate through the instrument menus described in this handbook.

	Home button (right hand switch housing).
	Mode button (left hand switch housing).
	Joystick left/right or up/down.
	Joystick Center (press).
	Selection arrow (right shown).
	Information Tray - left/right scroll using the joystick.
	Information Tray - up/down scroll using the joystick.
	Option available within the Information Tray - scroll using the joystick up/down.
	Short press (press and release) using the joystick center.
	Long press (press and hold) using the joystick center.
	Reset current feature. (only available with joystick long press).

Riding Modes

The riding modes allow adjustment of the throttle response (MAP), Anti-lock Braking System (ABS) and Traction Control (TC) settings to suit differing road conditions and rider preferences. Availability of the ABS, MAP and TC setting options vary between models. Up to six riding modes are available depending on the motorcycle model's specification.

Riding modes can be conveniently selected using the MODE button and joystick located on the left hand switch housing, while the motorcycle is stationary or moving, see page 56. If a riding mode is edited (other than the RIDER mode), the icon will change as shown below.

Default Icon	Rider Edited Icon	Description
		RAIN
		ROAD
		SPORT
		OFF-ROAD
		OFF-ROAD PRO
	-	RIDER

GENERAL INFORMATION

Riding Mode Selection

Warning

The selection of riding modes while the motorcycle is in motion requires the rider to allow the motorcycle to coast (motorcycle moving, engine running, throttle closed, clutch lever pulled in and no brakes applied) for a brief period of time.

Riding mode selection while the motorcycle is in motion should only be attempted:

- At low speed
- In traffic free areas
- On straight and level roads or surfaces
- In good road and weather conditions
- Where it is safe to allow the motorcycle to briefly coast.

Riding mode selection while the motorcycle is in motion **MUST NOT** be attempted:

- At high speeds
- While riding in traffic
- During cornering or on winding roads or surfaces
- On steeply inclined roads or surfaces
- In poor road/weather conditions
- Where it is unsafe to allow the motorcycle to coast.

Failure to observe this important warning will lead to loss of motorcycle control and an accident.

Warning

After selecting a riding mode, operate the motorcycle in an area free from traffic to gain familiarity with the new settings.

Do not loan your motorcycle to anyone as they may change the riding mode settings from the one you are familiar with, causing loss of motorcycle control and an accident.

Warning

If Traction Control (TC) has been disabled in the Main Menu as described on page 63 then all TC settings that were saved for all riding modes will be overridden.

TC will remain off regardless of the riding mode selection, until it has been re-enabled or the ignition has been switched off then on again.

If the traction control is disabled, the motorcycle will handle as normal but without traction control. In this situation accelerating too hard on wet/slippery road surfaces may cause the rear wheel to slip, and may result in loss of motorcycle control and an accident.

The riding mode will default to ROAD when the ignition is switched ON, if the OFF-ROAD, OFF-ROAD PRO or RIDER mode was active the last time the ignition was switched OFF with TC set to OFF-ROAD, OFF-ROAD PRO or OFF in the required mode. A warning message is shown stating that the riding mode has changed.

It also briefly allows the riding mode to be changed back to the original riding mode. Otherwise, the last selected riding mode will be remembered and activated when the ignition is switched ON.

If the mode icons are not shown when the ignition switch is in the ON position, make sure that the engine stop switch is in the RUN position.

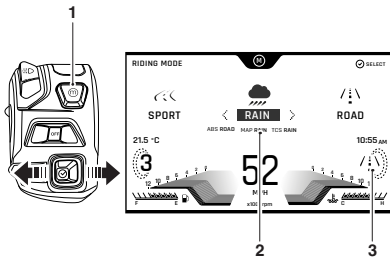

1. Mode button
2. New riding mode
3. Current riding mode

To select a riding mode:

- ▼ Press and release the MODE button on the left hand switch housing to activate the riding mode selection tray.
- ▼ The currently active riding mode icon is shown in the right hand side of the display.

To change the selected riding mode:

- ▼ Press the joystick left or right, or repeatedly press the MODE button until the required riding mode is highlighted in the center of the riding mode information tray.
- ▼ A brief press of the joystick center will select the required riding mode, and the riding mode icon in the right hand side of the display will change.
- ▼ The selected mode is activated once the following conditions for switching modes have been met:

Motorcycle Stationary - Engine Off

- ▼ The ignition is switched ON.
- ▼ The engine stop switch is in the RUN position.

Motorcycle Stationary - Engine Running

- ▼ Neutral gear is selected or the clutch is pulled in.

GENERAL INFORMATION

Motorcycle in Motion

Within 30 seconds of selecting a riding mode the rider must carry out the following simultaneously:

- ▼ Close the throttle.
- ▼ Make sure that the brakes are not engaged (allow the motorcycle to coast).

It is not possible to select OFF-ROAD, OFF-ROAD PRO or RIDER modes while the motorcycle is in motion, if the TC settings are set to OFF-ROAD, OFF-ROAD PRO or OFF in either of those modes. In this case, the motorcycle must be brought to a stop before the riding mode change can take place.

If a riding mode change is not completed, the riding mode icon will alternate between the previous riding mode and the newly selected riding mode until the change is complete or it is canceled.

The riding mode selection is now complete and normal riding can be resumed.

Main Menu

To access the Main menu:

- ▼ The motorcycle must be stationary with the ignition switched on.
- ▼ Press the HOME button on the right handlebar switch housing.
- ▼ Scroll the Main menu by pushing the joystick down/up until the required option is selected and then press the joystick center to confirm.

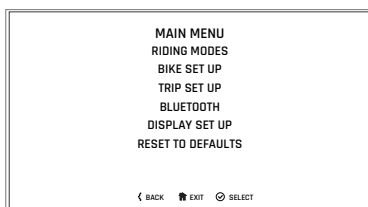

Main Menu Screen

The Main menu allows access to the following options:

Riding Modes

This menu allows configuration of the riding modes. For more information, see page 55.

Bike Set Up

This menu allows configuration of the different features of the motorcycle. For more information, see page 62.

Trip Set Up

This menu allows configuration of Trip 1 and Trip 2. For more information, see page 64.

Bluetooth® (if equipped)

This menu allows configuration of the Bluetooth® connectivity. For more information, see the My Triumph Connectivity Handbook.

The My Triumph Connectivity Handbook is also available on the Internet at: <https://www.triumphinstructions.com/>

Enter the part number 'A9820200' into the search field to access the handbook.

Display Set Up

This menu allows configuration of the display options. For more information, see page 66.







Reset to Defaults

This menu allows all instrument settings to be returned to the default setting. For more information, see page 72.

GENERAL INFORMATION

Riding Mode Configuration

Refer to the following table for the ABS, MAP and TC options available for each riding mode.

Riding Modes						
	RAIN 	ROAD 	SPORT ¹ 	OFF-ROAD ¹ 	OFF-ROAD PRO ² 	RIDER ³ 
Anti-lock Braking System (ABS)						
Road	●	●	●	∅	∅	●
Off-Road ¹	∅	∅	∅	●	○	∅
Off	∅	∅	∅	∅	●	∅
MAP (Throttle Response)						
Rain	●	○	∅	○	○	○
Road	○	●	○	○	○	●
Sport ¹	∅	○	●	○	○	○
Off-Road ¹	∅	∅	∅	●	●	∅
Traction Control (TC)						
Rain	●	○	∅	∅	∅	○
Road	○	●	○	∅	∅	●
Sport ¹	∅	○	●	∅	∅	○
Off-Road ¹	∅	∅	∅	●	○	○
Off ²	Via Menu	Via Menu	Via Menu	○	●	○
Off ³	Via Menu	Via Menu	Via Menu	∅	●	∅
Off ⁴	Via Menu	Via Menu	Via Menu	∅	●	○

¹ All Models except Tiger 850 Sport

² Tiger 900 Rally Pro Only

³ Tiger 850 Sport Only

⁴ All Models except Tiger 850 Sport and Tiger 900 Rally Pro

Key

●	Standard (Factory Default Setting)
○	Selectable Option
⊘	Option Not Available

Riding Modes

To access the Riding Modes menu:

- ▼ From the MAIN MENU, push the joystick down and select RIDING MODES.
- ▼ Press the joystick center to confirm.

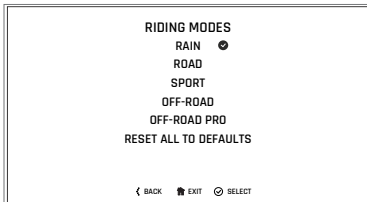

- ▼ Scroll down/up using the joystick to select the required riding mode. Press the joystick center to confirm.

- ▼ The relevant setting options for the selected riding mode are now shown.



- ▼ To change a setting, scroll down/up using the joystick until the required setting option is highlighted and press the joystick center to select.

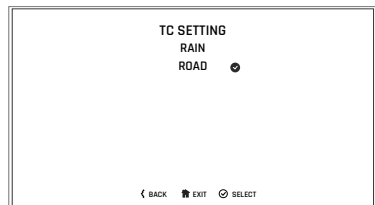

GENERAL INFORMATION

Bike Set Up Menu

The Bike Set Up menu allows configuration of the different features of the motorcycle.

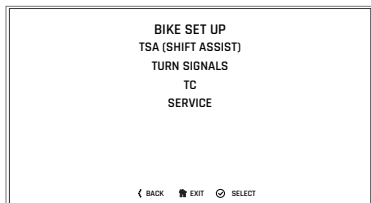

To access the Bike Set Up menu:

- ▼ From the MAIN MENU, push the joystick down and select BIKE SET UP.
- ▼ Press the joystick center to confirm.

Bike Set Up - TSA (Shift Assist) (if equipped)

Triumph Shift Assist (TSA) triggers a momentary engine torque change to allow gears to engage, without closure of the throttle or operation of the clutch. This feature works for both up-shifts and down-shifts of gear.

The clutch must be used for stopping and pulling away.

TSA will not operate if the clutch is applied or if an up-shift is attempted by mistake when in 6th gear.

It is necessary to use a positive pedal force to make sure there is a smooth gear shift.

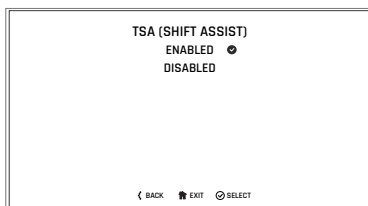

To enable/disable TSA:

- ▼ From the Bike Set Up menu, push the joystick down to select TSA (SHIFT ASSIST) and press the joystick to confirm.
- ▼ Push the joystick down/up to scroll between ENABLED and DISABLED.
- ▼ Press the joystick center to confirm the required selection.
- ▼ The display will then return to the Bike Set Up menu.

For more information on Triumph Shift Assist (TSA), see page 113.

Bike Set Up - Turn Signals

The turn signals can be set to Auto Basic, Auto Advanced or Manual mode.

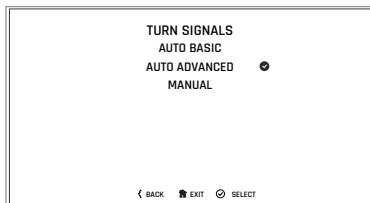

Selecting a Turn Signals Mode

To select the required turn signals mode:

- ▼ From the Bike Set Up menu, push the joystick down to select TURN SIGNALS and press the joystick center to confirm.
- ▼ Push the joystick down/up to scroll between AUTO BASIC, AUTO ADVANCED and MANUAL.
 - Auto Basic - The self-canceling function is on. The turn signals will activate for eight seconds and an additional 71 yards (65 meters).
 - Auto Advanced - The self-canceling function is on. A short press activates the turn signals for three flashes. A longer press activates the turn signals for eight seconds and an additional 71 yards (65 meters).
 - Manual - The self-canceling function is off. The turn signals must be manually canceled using the turn signal switch.
- ▼ Press the joystick center to confirm the required selection.
- ▼ The display will then return to the Bike Set Up menu.

Bike Set Up - Traction Control (TC)

The Traction Control (TC) system can be temporarily disabled. The Traction Control (TC) system cannot be permanently disabled, it will be automatically enabled when the ignition is turned off and then on again.

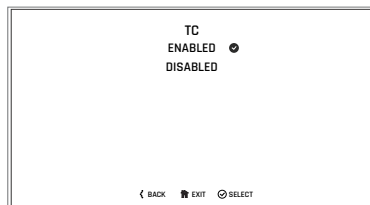

To disable or enable the TC system:

- ▼ From the BIKE SET UP menu, press the joystick center to select TC.
- ▼ Push the joystick down/up to scroll between ENABLED and DISABLED.
- ▼ Press the joystick center to select the required option.
- ▼ Once selected the display will return to the BIKE SET UP display.

GENERAL INFORMATION

Bike Set Up - Service

The service interval is set to a distance and/or time period.

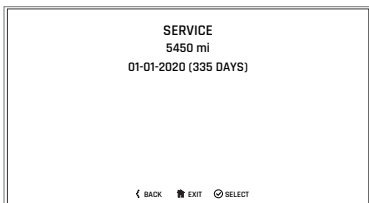

To review the service interval:

- ▼ From the BIKE SET UP menu, push the joystick down to select SERVICE.
- ▼ Press the joystick center to display the SERVICE information.

Trip Set Up

This menu allows the configuration of the trip meters.

To access the Trip Set Up menu:

- ▼ From the MAIN MENU, push the joystick down and select TRIP SET UP.
- ▼ Press the joystick center to confirm.

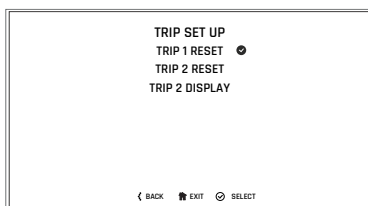

Selecting TRIP 1 RESET or TRIP 2 RESET allows the relevant trip meter to be configured manually or automatically. The trip meter set up procedure is the same for both trip meters.

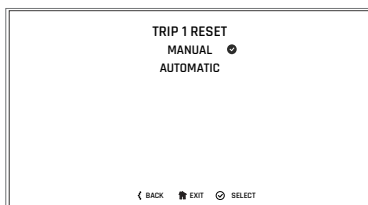

Manual reset will only reset the selected trip meter when the rider chooses to do so. For more information, see page 65.

Automatic reset will reset each trip meter after the ignition has been switched off for a set time. For more information, see page 65.

Trip meter 2 can be enabled or disabled. For more information, see page 66.

Trip Set Up - Manual Reset

To set the trip computer to reset manually:

- ▼ From the TRIP SETUP menu, push the joystick down and then press the joystick center to select TRIP 1 RESET or TRIP 2 RESET.
- ▼ Push the joystick center to select MANUAL.



There are two options:

- ▼ RESET NOW AND CONTINUE - Resets all trip meter data in the relevant trip meter.
- ▼ CONTINUE WITHOUT RESET - Any trip meter data in the relevant trip meter will not be reset.

Trip Set Up - Automatic Reset

To set the trip computer to automatically reset:

- ▼ From the TRIP SETUP menu, push the joystick down/up and then press the joystick center to select TRIP 1 RESET or TRIP 2 RESET.
- ▼ Push the joystick down/up to select AUTOMATIC and then press the joystick center to confirm.
- ▼ Using the joystick down/up, choose the timer setting and press the joystick center to confirm the required time limit.
- ▼ The required time limit is then stored in the trip memory. A tick is shown to indicate the selected option.
- ▼ When the ignition is turned off, the trip meter is set to zero when the time period has elapsed.

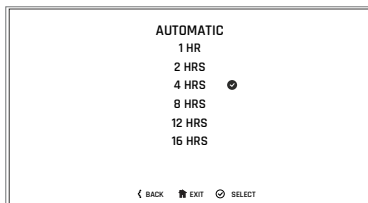

The following table shows two examples of the automatic trip reset functionality.

Ignition Turned Off	Selected Time Delay	Trip Meter Resets to Zero
10:30 hrs	4 HRS	14:30 hrs
18:00 hrs	16 HRS	10:00 hrs (next day)

GENERAL INFORMATION

Trip 2 Enable/Disable

Trip 2 meter can be enabled or disabled. If trip 2 meter is disabled, it will no longer be shown in the information tray.

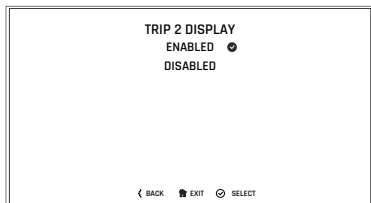

To enable or disable the Trip 2 meter:

- ▼ From the TRIP SET UP menu, push the joystick down/up to scroll to the TRIP 2 DISPLAY. Press the joystick center to confirm.
- ▼ Push the joystick down/up to scroll between ENABLED and DISABLED. Press the joystick center to confirm. A tick is shown to indicate the selected option.

Display Set Up Menu

The Display Set Up menu allows configuration of the different display screen options.

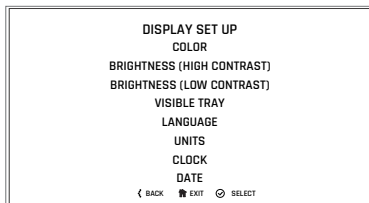

To access the Display Set Up menu:

- ▼ From the MAIN MENU, push the joystick down and select DISPLAY SET UP. Press the joystick center to confirm.
- ▼ Select the required option from the list to access the relevant information.

Display Set Up - Color

To select a different color for the display information:

- ▼ From the DISPLAY SET UP menu, push the joystick down/up to select COLOR.
- ▼ Press the joystick center to confirm.

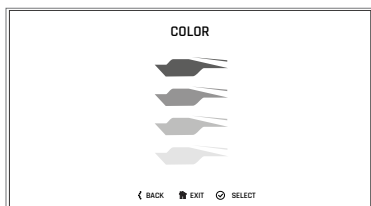

- ▼ Push the joystick down/up to scroll between the four different colored icons. There are four color options available; blue, green, yellow and white.
- ▼ Press the joystick center to select the required color.
- ▼ The new color is then applied to the instrument display for all styles. Press the HOME button to exit.

Display Set Up - Brightness

Tiger 850 Sport models only have the high contrast option available.

There are two brightness options to select from:

- ▼ High contrast - day time mode
- ▼ Low contrast - night time mode.

In bright sunlight, low contrast/brightness settings will be overridden to make sure that the instruments can be viewed at all times.

To adjust the brightness:

- ▼ From the DISPLAY SET UP menu, push the joystick down to select BRIGHTNESS (HIGH CONTRAST) or BRIGHTNESS (LOW CONTRAST) menu.
- ▼ Press the joystick center to select the required menu.

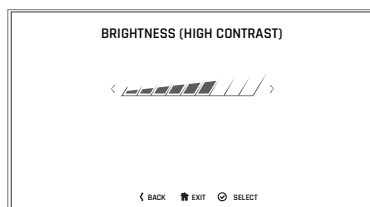

Brightness (High Contrast) Shown

- ▼ Push the joystick left/right to adjust the brightness.
- ▼ Press the joystick center to confirm the required level of brightness.
- ▼ Press the HOME button to return to the main display.

GENERAL INFORMATION

Display Set Up - Visible Tray

The Visible Tray menu allows the selection of the items to be shown in the information tray.

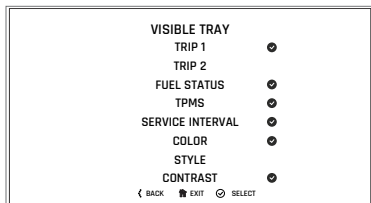

To select the Visible Tray menu:

- ▼ From the DISPLAY SET UP menu, push the joystick down to select the VISIBLE TRAY option.
- ▼ Press the joystick center to show the available options.
- ▼ Scroll the menu by moving the joystick down/up until the required option is highlighted.
- ▼ Press the joystick center to select/deselect the information trays.
- ▼ An information tray item with a tick next to it will be shown in the tray. An information tray item without a tick next to it will not be shown in the tray.

Display Set Up - Language

The Language menu allows the preferred language to be used as the instrument display language.



To select the required language for the instrument display:

- ▼ From the DISPLAY SET UP menu, push the joystick down to select the LANGUAGES option.
- ▼ Press the joystick center to confirm and display the available language options.
- ▼ Scroll the menu by pushing the joystick down/up until the required language option is highlighted.
- ▼ Press the joystick center to select/deselect the correct LANGUAGE. A tick is shown to indicate the selected option.
- ▼ Press the joystick center to confirm the language option.

Display Set Up - Units

The Units menu allows the selection of a preferred unit of measurement.

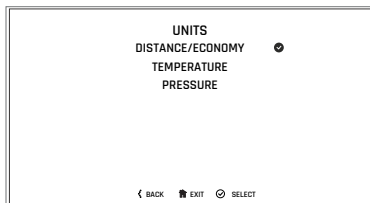

To select the required units of measurement:

- ▼ From the DISPLAY SET UP menu, push the joystick down and select UNITS.
- ▼ Press the joystick center to confirm.

To change the unit of measurement:

- ▼ Push the joystick down/up to highlight the required option (DISTANCE/ECONOMY, TEMPERATURE or PRESSURE).
- ▼ Press the joystick center to select. A tick is shown to indicate the selected option.
- ▼ Push the joystick down/up to select the required unit of measurement.
- ▼ Press the joystick center to confirm. A tick is shown to indicate the selected option.

The options available are:

Economy:

- ▼ Miles & MPG (UK)
- ▼ Miles & MPG (US)
- ▼ KM & L/100KM
- ▼ KM & KM/L

Temperature:

- ▼ °C
- ▼ °F

Pressure:

- ▼ PSI
- ▼ bar
- ▼ KPa

GENERAL INFORMATION

Display Set Up - Clock

The Clock menu allows the adjustment of the clock to be set to the local time.

To set the clock:

- ▼ From the Display Set Up menu, push the joystick down to select **CLOCK** and press the joystick center to confirm.
- ▼ Push the joystick down/up to select between either 12 Hr or 24 Hr clock and press the joystick center to confirm selection. A tick is shown to indicate the selected option.
- ▼ The clock will display in either 12 or 24 hour format. Once the clock format is set, the display will return to the **CLOCK** menu.

To set the time, push the joystick down/up to select **HOURS** or **MINUTES**.

To adjust the hour setting:

- ▼ Select **HOURS** on the display and press the joystick center. A tick will appear next to **HOURS** and the hour display will flash as shown below.
- ▼ Push the joystick down/up to set the hour. Press the joystick center to confirm.

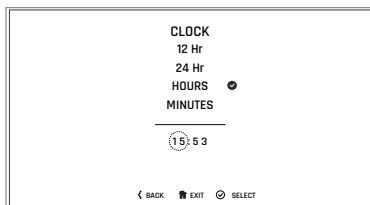

To adjust the minute setting:

- ▼ Select **MINUTES** on the display and press the joystick center. A tick will appear next to **MINUTES** and the minute display will flash as shown below.
- ▼ Push the joystick down/up to set the minute. Press the joystick center to confirm.

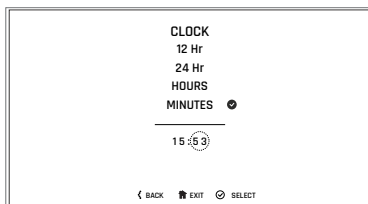

Display Set Up - Date

This function allows the date and date format to be adjusted.

To set the date and date format:

- ▼ From the DISPLAY SET UP menu, push the joystick down to select DATE and press the joystick center to confirm.
- ▼ Push the joystick down/up to select DATE FORMAT. Press the joystick center to confirm.

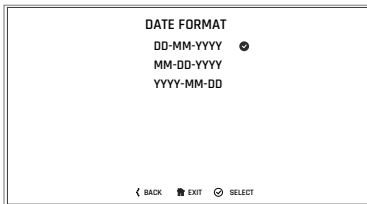

- ▼ Push the joystick down/up to select either of the date format options and press the joystick center to confirm selection. A tick is shown to indicate the selected option.
- ▼ Once the date format is set the display will return to the DATE menu.

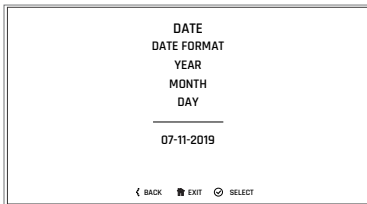

To set the date:

- ▼ From the DISPLAY SET UP menu, push the joystick down to select DATE and press the joystick center to confirm.
- ▼ Push the joystick down/up to select YEAR and press the joystick center to confirm. The YEAR display will flash.
- ▼ Push the joystick down/up to set the current year and then press the joystick center to confirm.
- ▼ To set the MONTH and DAY repeat the procedure used to set the year.

GENERAL INFORMATION

Reset to Defaults

The Reset to Default option allows the Main Menu display items to be reset to the default setting.



To reset the Main Menu display items:

- ▼ From the Main Menu, push the joystick down and select RESET TO DEFAULTS.
- ▼ Push the joystick down/up to select CONFIRM or CANCEL. Press the joystick center to confirm the selection.
 - Confirm - The following main menu settings and data will be reset to the factory default values
 - Riding Modes, Indicator Set Up, Trip Computers, Visible Trays, Language, Traction Control, Style, Display Brightness, Lap Timer settings and data.
 - Cancel - The main menu settings and data will remain unchanged and the display will return to the previous menu level.

Information Tray

Warning

When the motorcycle is in motion, only attempt to switch between the information tray modes or reset the fuel information under the following conditions:

- At low speed
- In traffic free areas
- On straight and level roads or surfaces
- In good road and weather conditions.

Failure to observe this important warning could lead to loss of motorcycle control and an accident.

The information tray allows easy access to different motorcycle status information. Any warning messages must first be acknowledged before the information tray can be accessed, see page 73.

The information tray appears in the top section of the display screen for styles 01, 02 and 03. It appears on the left hand side of the display screen for style 04.

To view the information trays in styles 01, 02 and 03, push the joystick down/up.

To view the information trays in style 04, push the joystick left/right.

The information tray contains the following information tray items:

- ▼ Warnings and Information Messages, see page 73
- ▼ Tachometer (if available)
- ▼ Brightness, see page 74
- ▼ Trip Meter, see page 74
- ▼ Fuel Consumption, see page 75
- ▼ Service Interval, see page 75
- ▼ Tire Pressure Monitoring System (TPMS), see page 76
- ▼ Contrast, see page 77
- ▼ Color, see page 78
- ▼ Style Select, see page 78
- ▼ Coolant (Style 04 only)
- ▼ Damping (if available), see page 79
- ▼ Suspension (Tiger 900 GT Pro only), see page 79
- ▼ Bluetooth® features, see My Triumph Connectivity Handbook.
- ▼ The My Triumph Connectivity Handbook is also available on the Internet at: <https://www.triumphinstructions.com/>
- ▼ Enter the part number 'A9820200' into the search field to access the handbook.

Different information tray items can be shown or hidden from the information tray. For further information, refer to page 68.

Warning Review

Any warnings and information messages are shown in the Warnings tray. An example is shown below.

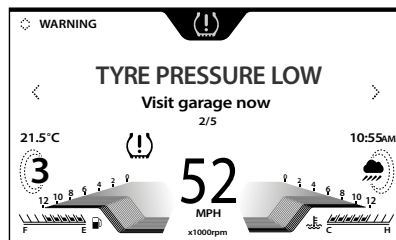

To view the warnings:

- ▼ Push the joystick down/up to scroll through the options until the warning review is shown.
- ▼ Push the joystick left/right to review each warning (if more than one). The warning counter will show the amount of warnings that are present.
- ▼ Push the joystick down/up to return to the information tray.

Low Battery Warning

If items such as heated grips are mounted and are on with the engine at idle, over a period of time, the battery voltage may drop below a predetermined voltage and a warning message will be shown in the Warnings tray.

GENERAL INFORMATION

Brightness

The Brightness information tray allows the brightness of the display screen to be adjusted. In bright sunlight, low brightness settings will be overridden to make sure that the instruments can be viewed at all times.

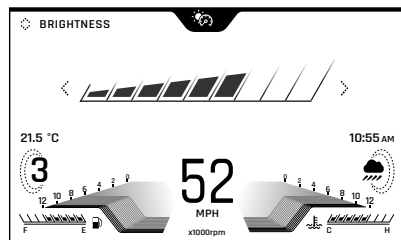

To adjust the brightness of the display screen:

- ▼ Push the joystick left/right to increase/decrease the level of brightness.
- ▼ Press the joystick center to confirm the required level of brightness.

Note

Do not cover the light sensor on the display screen as this will stop the screen brightness and contrast from working correctly.

Trip Meter

There are two trip meters that can be accessed and reset in the information tray.

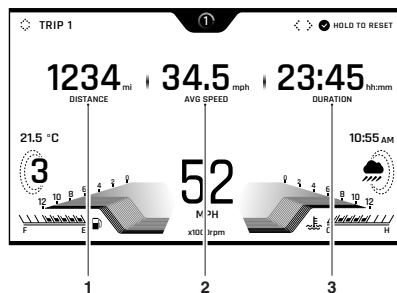

1. Distance traveled
2. Average speed
3. Duration of trip

To view a specific trip meter:

- ▼ Push the joystick down/up to scroll through the information tray items until Trip 1 meter is shown.
- ▼ Select TRIP 1 or TRIP 2 by pushing the joystick left/right.

TRIP 2 meter can be shown or hidden from the information tray. For more information, see page 66.

To reset a trip meter:

- ▼ Select the trip meter to be reset.
- ▼ Press and hold the joystick center for more than one second.
- ▼ The trip meter will then be reset.

The trip meter can also be reset from the Main menu, see page 65.

Fuel Consumption

The Fuel Consumption information tray shows fuel consumption information. After refueling, the fuel gage and range to empty information will be updated only while riding the motorcycle. Depending on the riding style, updating could take up to five minutes.

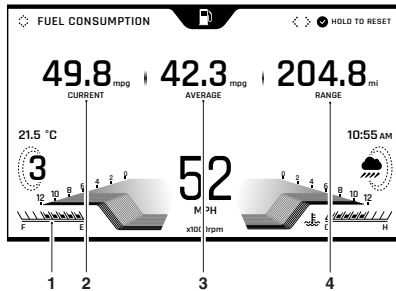

1. Fuel gage
2. Current fuel consumption
3. Average fuel consumption
4. Range to empty

Current Fuel Consumption

This is an indication of the fuel consumption at an instant in time. If the motorcycle is stationary, --.- will be shown in the display area.

Average Fuel Consumption

This is an indication of the average fuel consumption. After being reset the display will show dashes until 0.1 miles/km has been covered.

Range to Empty

This is an indication of the predicted distance that can be traveled on the remaining fuel in the tank.

Reset

To reset the average fuel consumption, press and hold the joystick center.

Odometer and Service

The Odometer and Service information tray shows the odometer, and the distance and days remaining before the next service is recommended.

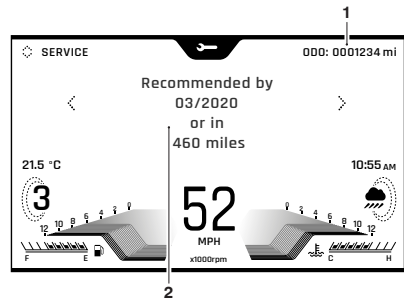

1. Odometer
2. Service information

GENERAL INFORMATION

Tire Pressure Monitoring System (TPMS) (if equipped)

Warning

Stop the motorcycle if the tire pressure warning light illuminates.

Do not ride the motorcycle until the tires have been checked and the tire pressures are at their recommended pressure when cold.

The Tire Pressure Monitoring System (TPMS) information tray is with the Service information tray.

To view the Tire Pressure Monitoring System (TPMS):

- ▼ Push the joystick down/up and scroll the Service information tray.
- ▼ Select Tire Pressure by pushing the joystick left/right.

The Tire Pressure Monitoring System (TPMS) information tray shows the front and rear tire pressures.

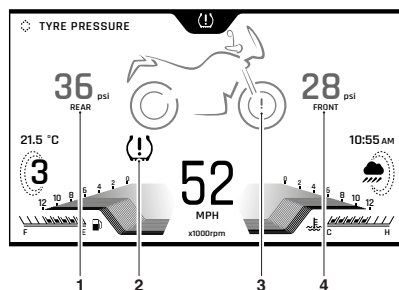

1. Rear tire pressure indicator
2. Tire pressure warning light
3. Low front tire pressure warning shown
4. Front tire pressure indicator

Tire Pressure Warning Light

The tire pressure warning light will only illuminate when the front or rear tire pressure is below the recommended pressure. It will not illuminate if the tire is over inflated.

Front Tire Pressure Indicator

This shows the current front tire pressure.

Rear Tire Pressure Indicator

This shows the current rear tire pressure.

Low Tire Pressure

The front or rear tire will be highlighted on the motorcycle image to indicate that the tire pressure is below the recommended pressure.

For more information on TPMS and tire pressures, see page 170.

Screen Contrast

The Contrast information tray allows the display screen contrast to be adjusted.

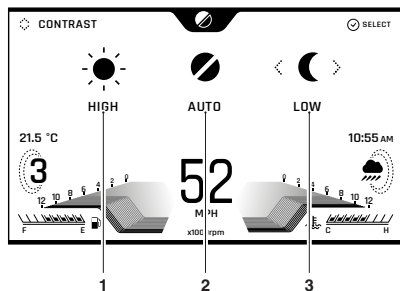

1. High contrast option
2. Auto contrast option
3. Low contrast option

There are three options available:

- ▼ HIGH - This option locks the display screen to the white background version of each display screen style for maximum visibility during the day.
- ▼ AUTO - This option uses the instrument light sensor to adjust the contrast to the most suitable setting. In bright sunlight, low contrast settings will be overridden to make sure the instruments can be viewed at all times.
- ▼ LOW - This option locks the display screen to the black background version of each display screen style for maximum visibility at night time.

Note

Tiger 850 Sport models only have the HIGH contrast option available.

To select an option:

- ▼ Push the joystick left/right to select the HIGH, AUTO or LOW contrast option and press the joystick center to confirm.
- ▼ If the rider defined brightness setting is suitable this will be used, see page 67.

Note

Do not cover the light sensor on the display screen as this will stop the screen brightness and contrast from working correctly.

GENERAL INFORMATION

Color

The Color information tray allows a different color to be applied to the current style. There are four color options available; blue, green, yellow and white.

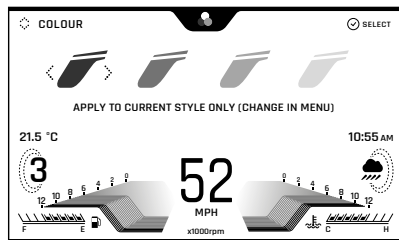

To apply a different color to the current style:

- ▼ Push the joystick left/right to select the required color.
- ▼ Press the joystick center to confirm the required color.
- ▼ The new color is then applied to the current style.
- ▼ To apply a color to all styles, see page 67.

Style Select

The Style Select information tray allows a different style to be applied to the display screen.

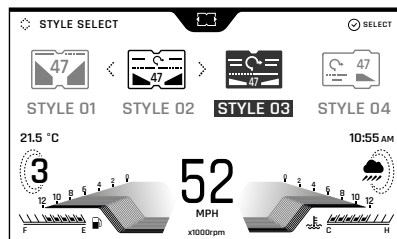

Style Select Information Tray (Style 03 Selected)

To change the display screen style:

- ▼ Push the joystick left/right to select the required style and then press the joystick center to confirm.

Damping

Tiger 900 GT Pro Only

The Damping information tray allows the suspension damping to be adjusted for the ride.

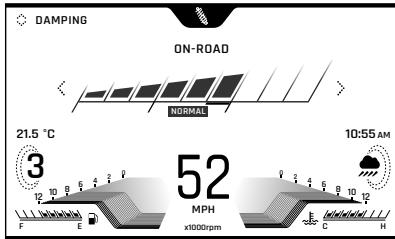

To adjust the suspension damping:

- ▼ Push the joystick left/right to decrease/increase the level of damping. There are 3 levels available; comfort, normal and sport.
- ▼ Press the joystick center to confirm the required level of damping.

Suspension

Tiger 900 GT Pro Only

The Suspension information tray allows the selection of predetermined suspension settings.

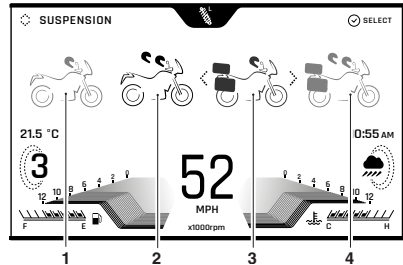

1. Rider only setting
2. Rider and passenger setting
3. Rider and luggage setting
4. Rider, passenger and luggage setting

To select a predefined suspension setting:

- ▼ Push the joystick left/right to highlight the required suspension setting.
- ▼ Press the joystick center to confirm the required suspension setting.

Cruise Control

All Models except Tiger 850 Sport

Warning

Cruise control must only be used where you can ride safely at a steady speed.

Cruise control should not be used when riding in heavy traffic, on roads with sharp/blind bends or when they are slippery.

Using cruise control in heavy traffic, on roads with sharp/blind bends or when they are slippery, may result in loss of motorcycle control and an accident.

Warning

This Triumph motorcycle should be operated within the legal speed limits for the particular road traveled.

Operating a motorcycle at high speeds can be potentially dangerous since the time available to react to given traffic situations is greatly reduced as road speed increases.

Always reduce speed in potentially hazardous driving conditions such as bad weather or heavy traffic.

Warning

Only operate this Triumph motorcycle at high speed in closed-course, on-road competition or on closed-course racetracks.

High speed operation should only then be attempted by riders who have been instructed in the techniques necessary for high speed riding and are familiar with the motorcycle's characteristics in all conditions.

High speed operation in any other circumstances is dangerous and will lead to loss of motorcycle control and an accident.

Note

Cruise control may not function if there is a malfunction with the ABS system and the ABS warning light is illuminated.

Cruise control will continue to function if a riding mode is selected with ABS set to Off-Road or Off.

Cruise control will continue to function if ABS has been disabled.

The cruise control buttons are located on the left hand switch housing and can be operated with minimum movement by the rider.

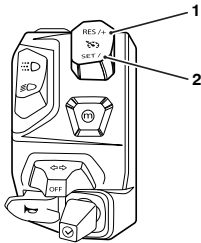

1. Cruise control RES/+ button
2. Cruise control SET/- button

Cruise control can be switched on or off at any time but it cannot be activated until all the conditions described on page 81 have been met.

Activating Cruise Control

To turn on the cruise control system, press the SET/- button. The cruise control symbol will be shown in the display screen. The cruise control set speed will be shown as '--' indicating that a speed has not yet been set.

To activate cruise control, the following conditions have to be met:

- ▼ The motorcycle must be traveling at a speed between 19 to 100 mph (30 to 160 km/h).
- ▼ The motorcycle must be in 3rd gear or higher.

- ▼ Once these conditions have been met, press the SET/- button to activate cruise control. The cruise control symbol will be shown in a green light in the TFT display to indicate that cruise control is now active.

The word SET will be shown next to the cruise control symbol. The cruise control set speed will be shown and the cruise control light will illuminate in the tachometer indicating that cruise control is active.

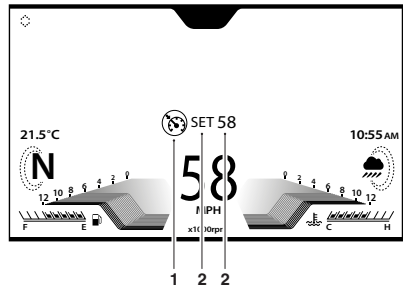

1. Cruise control symbol
2. Cruise control set indicator
3. Cruise control set speed

The cruise control system will maintain the set speed until:

- ▼ The set speed is adjusted as described on page 82.
- ▼ Cruise control is deactivated as described on page 82.

GENERAL INFORMATION

Adjusting the Set Speed While in Cruise Control

To adjust the set speed while in cruise control, press and release the:

- ▼ RES/+ button to increase the speed
- ▼ SET/- button to decrease the speed.

Each press of the buttons will adjust the speed by 1 mph or 1 km/h. If the buttons are held, the speed continuously increases or decreases in single digit increments.

Stop pressing the adjust button when the required speed is shown in the display.

Note

The cruise control set speed display will flash until the new set speed has been achieved.

If riding up a steep incline and cruise control is unable to maintain the set speed, the cruise control set speed display will flash until the motorcycle has regained the set speed.

An alternative way to increase the speed in cruise control is to accelerate to the required speed using the throttle grip and then press the SET/- button.

Deactivating Cruise Control

The cruise control can be deactivated by one of the following methods:

- ▼ Roll the throttle twist grip fully forward.
- ▼ Pull the clutch lever.
- ▼ Operate the front or rear brake.
- ▼ Increase speed by using the throttle for more than 60 seconds.

Upon deactivation, the cruise control light will go out in the tachometer but the SET indicator and set speed will still be shown in the display screen, indicating that the cruise control set speed has been stored.

The cruise control set speed can be resumed as described on page 83, provided the cruise control has not been deactivated by turning the ignition switch to the OFF position.

Resuming the Cruise Control Set Speed

Warning

When resuming cruise control, always make sure that the traffic conditions are suitable for the set speed.

Using cruise control in heavy traffic, on roads with sharp/blind bends or when they are slippery, may result in loss of motorcycle control and an accident.

Cruise control will be deactivated if one of the following actions has been taken:

- ▼ Roll the throttle twist grip fully forward.
- ▼ Pull the clutch lever.
- ▼ Operate the front or rear brake.
- ▼ Increase speed by using the throttle grip for more than 60 seconds.

The cruise control set speed can be resumed by pressing and releasing the RES/+ button provided a set speed has been stored.

The motorcycle must be traveling at a speed between 19 to 100 mph (30 to 160 km/h) and be in 3rd gear or higher.

A stored set speed is indicated by the word SET next to the cruise control symbol in the display screen.

The stored set speed will remain in the cruise control memory until the ignition switch has been turned to the OFF position.

Note

The cruise control set speed display will flash until the resumed set speed has been achieved.

Traction Control (TC)

 **Warning**

The traction control and optimized cornering traction control systems are not a substitute for riding appropriately for the prevailing surface and weather conditions. The systems cannot prevent loss of traction due to:

- excessive speed when entering turns
- accelerating at a sharp lean angle
- braking.

Traction control or optimized cornering traction control cannot prevent the front wheel from slipping.

Failure to observe any of the above may result in loss of motorcycle control and an accident.

 **Warning**

If the traction control system is not functioning, care must be taken when accelerating and cornering on wet/slippery road surfaces to avoid rear wheel spin.

In the event of a fault, the traction control disabled warning light may be accompanied by the engine management system malfunction indicator light and/or the ABS warning light.

Do not continue to ride for longer than is necessary with any of the above warning lights illuminated. Contact an authorized Triumph dealer as soon as possible to have the fault checked and rectified.

 **Warning** Continued

Hard acceleration and cornering in this situation may cause the rear wheel to spin resulting in loss of motorcycle control and an accident.

All motorcycles are equipped with Traction Control (TC). Traction control is a system that helps to maintain traction when accelerating on wet/slippery road surfaces. If sensors detect that the rear wheel is losing traction (slipping), the traction control system will engage and alter the engine power until traction to the rear wheel has been restored. The traction control indicator light will flash while it is engaged and a change to the sound of the engine may be noticed. For information on the traction control indicator light operation, see page 45.

Note

Traction control may not always be active depending on the riding mode selected.

Traction control and optimized cornering traction control (if equipped) may not function if there is a malfunction with the ABS system. In this situation, the warning lights for the ABS, traction control and the MIL may be illuminated.

Optimized Cornering Traction Control (if equipped)

Warning

If a fault occurs with the optimized cornering traction control system, the traction control disabled warning light will illuminate and a message will be shown in the display.

In this situation, the traction control system will continue to operate but without the optimized cornering function, provided that:

- There are no other faults with the traction control system.
- Traction control has NOT been disabled (see Bike Setup on page 63 or Riding Mode Configuration on page 60).

Care must be taken when accelerating and cornering on wet/slippery road surfaces to avoid rear wheel spin.

In the event of a fault, the traction control disabled warning light may be accompanied by the engine management system malfunction indicator light and/or the ABS warning light.

Do not continue to ride for longer than is necessary with any of the above warning lights illuminated. Contact an authorized Triumph dealer as soon as possible to have the fault checked and rectified.

Hard acceleration and cornering in this situation may cause the rear wheel to spin resulting in loss of motorcycle control and an accident.

Optimized cornering traction control is a system designed to provide increased control should the traction control be activated while the motorcycle is leaning in a corner.

The system constantly monitors the lean angle of the motorcycle and adapts the level of traction control intervention to maintain rear wheel traction during cornering.

Optimized cornering traction control is not active when in Off-Road or Off-Road Pro mode.

Note

Traction control may not always be active depending on the riding mode selected.

Traction control and optimized cornering traction control (if equipped) may not function if there is a malfunction with the ABS system. In this situation, the warning lights for the ABS, traction control and the MIL may be illuminated.

For full details of the traction control disabled warning light operation and its associated instrument warning messages, see page 45.

Traction Control Settings

 **Warning**

If the traction control is disabled, the motorcycle will handle as normal but without traction control.

In this situation accelerating too hard on wet/slippery road surfaces may cause the rear wheel to slip which may result in loss of motorcycle control and an accident.

The traction control system can be disabled as described in Bike Setup on page 63, or set to the conditions described in Riding Mode Configuration on page 60.

Tire Pressure Monitoring System (TPMS) (if equipped)

 **Warning**

The daily check of tire pressures must not be excluded because of the installation of the Tire Pressure Monitoring System (TPMS).

Check the tire pressure when the tires are cold using an accurate tire pressure gage, see the Tire section for more information.

Use of the TPMS system to set inflation pressures may lead to incorrect tire pressures leading to loss of motorcycle control and an accident.

Function

Tire pressure sensors are mounted to the front and rear wheels. These sensors measure the air pressure inside the tire and transmit pressure data to the instruments. These sensors will not transmit the data until the motorcycle is traveling at a speed greater than 12 mph (20 km/h). Two dashes will be shown in the display area until the tire pressure signal is received.

An adhesive label will be mounted to the wheel rim to indicate the position of the tire pressure sensor, which is near the valve.

Note

For all motorcycles models without the Tire Pressure Monitoring System (TPMS) installed as standard, it is available as an accessory equipped item. It must be installed by your authorized Triumph dealer. The TPMS display on the instruments will only be activated when the system has been installed.

Tire Pressure Warning Light (if equipped with TPMS)

Warning

Stop the motorcycle if the tire pressure warning light illuminates.

Do not ride the motorcycle until the tires have been checked and the tire pressures are at their recommended pressure when cold.



The tire pressure warning light works in conjunction with the Tire Pressure Monitoring System, see page 48.

The warning light will only illuminate when the front or rear tire pressure is below the recommended pressure. It will not illuminate if the tire is over inflated.

When the warning light is illuminated, the Tire Pressure display will show which tire is the deflated tire. It will also show the tire pressure.

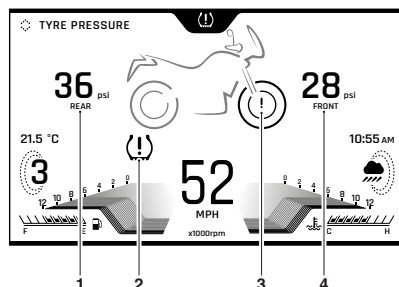

1. Rear tire pressure indicator
2. TPMS warning light
3. Low front tire pressure warning shown
4. Front tire pressure indicator

The tire pressure at which the warning light illuminates is temperature compensated to 68°F (20°C) but the numeric pressure display associated with it is not (see page 169). Even if the numeric display seems at or close to the standard tire pressure when the warning light is on, a low tire pressure is indicated and a puncture is the most likely cause.

GENERAL INFORMATION

Tire Pressure Sensor Serial Number

The serial number for the tire pressure sensor is printed on a label attached to the sensor. This number may be required by your authorized Triumph dealer for service or diagnostics.

When the tire pressure monitoring system is being installed to the motorcycle, make sure that your authorized Triumph dealer records the serial numbers of the front and rear tire pressure sensors in the spaces provided below.

Front Tire Pressure Sensor

Rear Tire Pressure Sensor

Tire Pressures

Warning

The Tire Pressure Monitoring System (TPMS) is not to be used as a tire pressure gage when adjusting the tire pressures.

For correct tire pressures, always check the tire pressures when the tires are cold using an accurate tire pressure gage.

Use of the TPMS system to set inflation pressures may lead to incorrect tire pressures leading to loss of motorcycle control and an accident.

Caution

Do not use anti puncture fluid or any other item likely to obstruct air flow to the TPMS sensor's orifices. Any blockage to the air pressure orifice of the TPMS sensor during operation will cause the sensor to become blocked, causing irreparable damage to the TPMS sensor assembly.

Damage caused by the use of anti puncture fluid or incorrect maintenance is not considered a manufacturing defect and will not be covered under warranty.

Always have your tires mounted by your authorized Triumph dealer and inform them that tire pressure sensors are installed on the wheels.

The tire pressures shown on the instrument panel indicate the actual tire pressure at the time of selecting the display. This may differ from the inflation pressure set when the tires are cold because tires become warmer during riding, causing the air in the tire to expand and the pressure to increase. The cold inflation pressures specified by Triumph take account of this.

Only adjust tire pressures when the tires are cold using an accurate tire pressure gage (see page 170), and do not use the tire pressure display on the instruments.

Replacement Tires

When replacing tyres, always have an authorized Triumph dealer fit your tyres and make sure they are aware that tyre pressure sensors are fitted to the wheels.

Sensor Batteries

When the battery voltage in a pressure sensor is low, a message will be shown in the instrument display and the TPMS symbol or message will indicate which wheel sensor has the low battery voltage. If the batteries are completely flat, only dashes will be shown in the instrument display, the red TPMS warning light will be on and the TPMS symbol will flash continuously. Contact your authorized Triumph dealer to have the sensor replaced and the new serial number recorded in the spaces provided on page 88.

With the ignition switch turned to the ON position, if the TPMS symbol flashes continuously or the TPMS warning light remains on there is a fault with the TPMS system. Contact your authorized Triumph dealer to have the fault rectified.

GENERAL INFORMATION

Fuel



Fuel Grade

Triumph motorcycles are designed to run on unleaded gasoline with a CLC or AKI octane rating $(R+M)/2$ of 87 or higher. Federal regulations require that pumps delivering unleaded gasoline are marked 'UNLEADED' and that the Cost of Living Council (CLC) or Anti-Knock Index (AKI) octane rating is also displayed. These ratings are an average of the Research Octane Number (RON) and the Motor Octane Number (MON).

Ethanol

In Europe, Triumph motorcycles are compatible with Ethanol E5 and E10 (5% and 10% Ethanol) unleaded fuel.

In all other markets Ethanol up to E25 (25% Ethanol) may be used.

Engine Calibration

In certain circumstances engine calibration may be required. Always refer to your authorized Triumph dealer.

⚠ Caution

The motorcycle can be permanently damaged if it is allowed to operate with the incorrect grade of fuel or incorrect engine calibration.

Always make sure the fuel used is of the correct grade and quality.

Damage caused by using the incorrect fuel or engine calibration is not considered a manufacturing defect and will not be covered under warranty.

⚠ Caution

The exhaust system for this motorcycle is equipped with a catalytic converter to help reduce exhaust emission levels.

Use of leaded fuel will damage the catalytic converter. In addition, the catalytic converter can be permanently damaged if the motorcycle is allowed to run out of fuel or if the fuel level is allowed to get very low.

Always make sure you have adequate fuel for your trip.

Note

The use of leaded fuel is illegal in some countries, states or territories.

Note

If 'knocking' or 'pinging' occurs at a steady engine speed under normal load, use a different brand of gasoline or gasoline which has a higher octane rating.

Oxygenated Gasoline

To help in meeting clean air standards, some areas of the U.S. use oxygenated gasoline to help reduce harmful emissions. These gasolines are a blend of conventional gasoline and another compound such as alcohol. This Triumph motorcycle will give its best performance when using unleaded gasoline. However, the following should be used as a guide if you use any oxygenated fuels.

Ethanol

Ethanol fuel is a mixture of 10% Ethanol and 90% gasoline and is often described under the names 'gasohol', 'Ethanol enhanced', or 'contains Ethanol'. This fuel may be used in your Triumph motorcycle.

MTBE (Methyl Tertiary Butyl Ether)

The use of gasolines containing up to 15% MTBE (Methyl Tertiary Butyl Ether) is permitted in this Triumph motorcycle.

Methanol

Fuels containing methanol should not be used as damage to components in the fuel system can be caused by contact with methanol.

Note

Because of the generally higher volatility of oxygenated fuels, starting, engine response and fuel consumption may be adversely affected by their use. Should any of these difficulties be experienced, run the motorcycle on normal unleaded gasoline.

Refueling

 **Warning**

To help reduce hazards associated with refueling, always observe the following fuel safety instructions:

- Gasoline (fuel) is highly flammable and can be explosive under certain conditions. When refueling, turn the ignition switch to the OFF position.
- Do not smoke.
- Do not use a mobile telephone.
- Make sure the refueling area is well ventilated and free from any source of flame or sparks. This includes any appliance with a pilot light.
- Never fill the tank until the fuel level rises into the filler neck. Heat from sunlight or other sources may cause the fuel to expand and overflow creating a fire hazard.
- After refueling always check that the fuel filler cap is correctly closed.
- Because gasoline (fuel) is highly flammable, any fuel leak or spillage, or any failure to observe the safety advice given above will lead to a fire hazard, which could cause damage to property, injury to persons or death.

Fuel Tank Cap

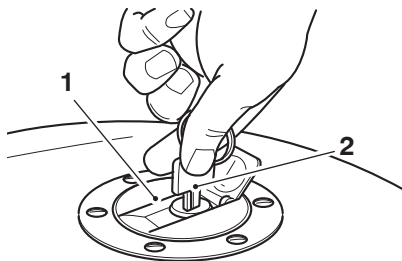

1. Fuel tank cap
2. Key

To open the fuel tank cap, lift up the flap covering the lock itself. Insert the key into the lock and turn the key clockwise.

To close and lock the cap, push the cap down into place with the key inserted, until the lock clicks into place. Withdraw the key and close the key cover.

 **Caution**

Closing the cap without the key inserted will damage the cap, tank and lock mechanism.

Filling the Fuel Tank

Warning

Overfilling the tank can lead to fuel spillage.

If fuel is spilled, thoroughly clean up the spillage immediately and dispose of the materials used safely.

Take care not to spill any fuel on the engine, exhaust pipes, tires or any other part of the motorcycle.

Because fuel is highly flammable, any fuel leak or spillage, or any failure to observe the safety advice given above may lead to a fire hazard, which could cause damage to property and injury or death to persons.

Fuel spilled near to, or onto the tires will reduce the tires' ability to grip the road. This will result in a dangerous riding condition potentially causing loss of motorcycle control and an accident.

Caution

Avoid filling the tank in rainy or dusty conditions where airborne material can contaminate the fuel.

Contaminated fuel may cause damage to fuel system components.

Fill the fuel tank slowly to help prevent spillage. Do not fill the tank to a level above the bottom of the filler neck. This will make sure there is enough air space to allow for fuel expansion if the fuel inside the tank expands through absorption of heat from the engine or from direct sunlight.

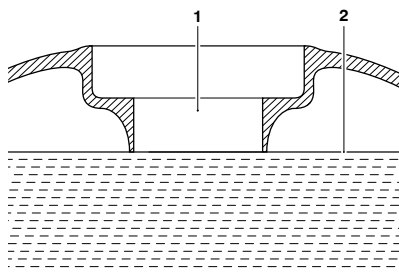

1. Fuel filler neck
2. Maximum fuel level

After refueling always check that the fuel filler cap is correctly closed.

GENERAL INFORMATION

Stands

Side Stand

Warning

The motorcycle is equipped with an interlock system to prevent it from being ridden with the side stand in the down position.

Never attempt to ride with the side stand down or interfere with the interlock mechanism as this will cause a dangerous riding condition leading to loss of motorcycle control and an accident.

Warning

Do not lean, sit or climb on the motorcycle when it is supported on the side stand.

This may cause the motorcycle to fall over leading to motorcycle damage and an accident.

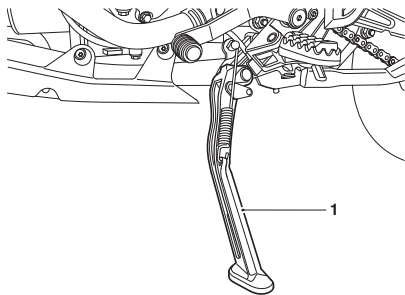

1. Side stand

The motorcycle is equipped with a side stand on which the motorcycle can be parked.

Whenever the side stand is used, before riding, always make sure that the side stand is fully up after first sitting on the motorcycle.

When parking the motorcycle using the side stand, always turn the handlebars fully to the left and leave the motorcycle in first gear.

For instructions on safe parking, refer to the How to Ride the Motorcycle section.

Center Stand (if equipped)**⚠ Warning**

Do not lean, sit or climb on the motorcycle when it is supported on the center stand.

This may cause the motorcycle to fall over leading to motorcycle damage and an accident.

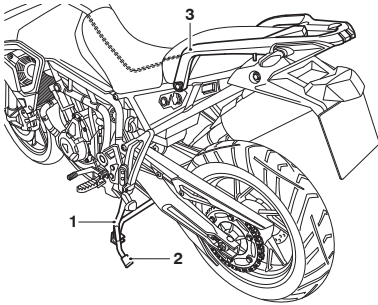

1. Center stand
2. Foot finder
3. Rear grab rail

To set the motorcycle on the center stand:

- ▼ Hold the motorcycle upright.
- ▼ Step down firmly on the foot finder part of the stand.
- ▼ Lift the motorcycle up and to the rear using the rear grab rail as a handhold.

For instructions on safe parking, refer to the How to Ride the Motorcycle section.

⚠ Caution

Do not use body panels or the seat as a handhold when placing the motorcycle on the center stand as this will cause damage.

Seats

Seat Care

⚠ Caution

To prevent damage to the seats or seat covers, care must be taken not to drop the seats.

Do not lean the seats against the motorcycle or any surface which may damage the seats or seat covers. Instead, place the seats, with the seat cover facing upwards, on a clean, flat surface which is covered with a soft cloth.

Do not place any item on the seats which may cause damage or staining to the seat covers.

For more information on seat cleaning, see page 193.

Seat Lock

⚠ Warning

To prevent detachment of the seat during riding, after installation always grasp the seat and pull firmly upwards.

If the seat is not correctly secured in the lock, it will detach from the lock.

A loose or detached seat may cause loss of motorcycle control and an accident.

⚠ Caution

The motorcycle must not be ridden with the key in the seat lock.

Always lock the seat and remove the key before riding the motorcycle.

The seat lock is located on the left hand side of the motorcycle, on the frame below the seat.

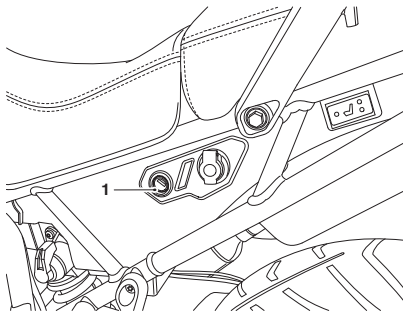

1. Seat lock

The seat can be removed to gain access to the battery, storage area and tool kit.

Passenger Seat

Warning

The rider's seat is only correctly retained and supported once the passenger seat is correctly installed.

Never ride the motorcycle with the passenger seat detached or removed, as the rider's seat will not be secure and may move.

A loose or detached seat may cause loss of motorcycle control and an accident.

Warning

To prevent detachment of the seat during riding, after installation always grasp the seat and pull firmly upwards.

If the seat is not correctly secured in the lock, it will detach from the lock.

A loose or detached seat may cause loss of motorcycle control and an accident.

The passenger seat must be removed before the rider's seat can be removed. There is also a small storage compartment located beneath the passenger seat, see page 102.

Passenger Seat Removal

To remove the passenger seat:

- ▼ Insert the ignition key into the seat lock, see page 96.
- ▼ Turn the ignition key counterclockwise while pressing down on the rear of the seat. This will release the seat from its lock and allow it to be slid rearwards.
- ▼ If equipped with heated seats, rotate the passenger seat and rest it on the rider's seat. Disconnect the heated seat's electrical connector.
- ▼ Remove the seat from the motorcycle.

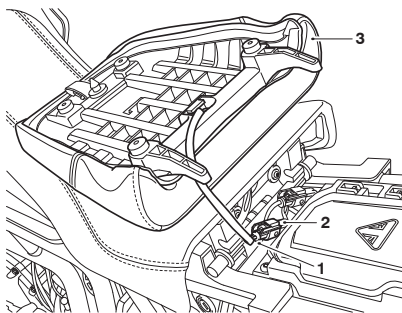

1. Electrical connector
2. Clip
3. Heated passenger seat

Passenger Seat Installation

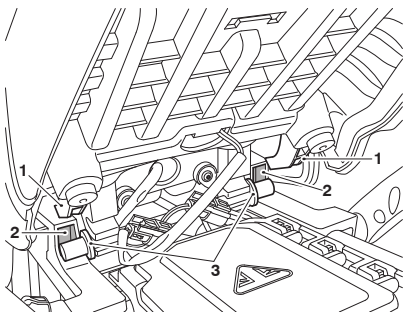

1. Passenger seat brackets
2. Locating feature
3. Rider's seat mountings

To install the passenger seat:

- ▼ Reconnect the heated seat's electrical connector (if equipped).
- ▼ Push down firmly on the rear of the rider seat and hold.
- ▼ Engage the seat's two brackets into the locating feature.
- ▼ Press down at the rear to engage in the seat lock.

Rider's Seat

Warning

The rider's seat is only correctly retained and supported once the passenger seat is correctly installed.

Never ride the motorcycle with the passenger seat detached or removed, as the rider's seat will not be secure and may move.

A loose or detached seat may cause loss of motorcycle control and an accident.

Rider's Seat Removal

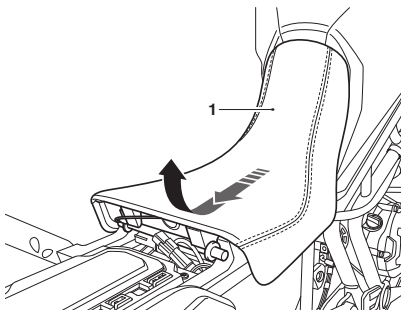

1. Rider's seat

To remove the rider's seat:

- ▼ Remove the passenger seat (see page 97).
- ▼ Grasp the rider's seat on either side, and slide it rearwards and upwards.
- ▼ If equipped with heated seats, disconnect the heated seat's electrical connector for complete removal from the motorcycle.

Rider's Seat Installation

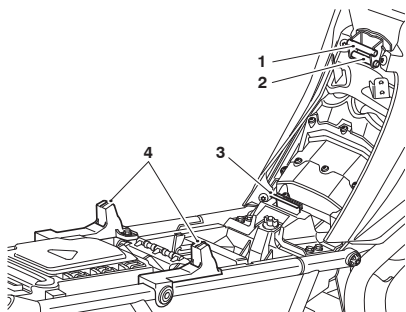

1. Upper bar
2. Lower bar
3. Seat bridge
4. Seat supports

To install the seat:

- ▼ Reconnect the heated seat's electrical connector (if equipped).
- ▼ Position the seat tongue under the upper bar on the fuel tank for the high seat position, or under the lower bar on the fuel tank for the low seat position (see page 99).
- ▼ Engage the seat's front rail into the seat bridge at the rear of the fuel tank and lower the rear rail onto the seat supports.
- ▼ Push down firmly on the rear of the seat and hold.
- ▼ Reinstall the passenger seat (see page 97).

Rider's Seat Height Adjustment

 **Warning**

Always adjust both seat height adjusters. Adjusting only one height adjuster may prevent correct installation of the seat.

Riding the motorcycle with an incorrectly mounted seat may cause loss of motorcycle control and an accident.

 **Warning**

After adjusting the seat height, operate the motorcycle in an area free from traffic to gain familiarity with the new seat position.

Riding the motorcycle with the seat in an unfamiliar position may cause loss of motorcycle control and an accident.

The rider's seat is adjustable for height by approximately 0.8 in (20 mm).

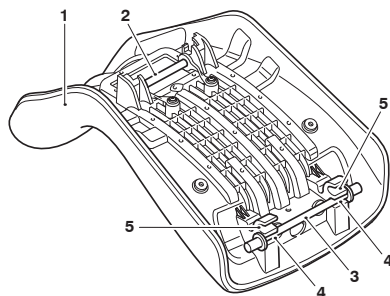

1. Rider's seat
2. Front seat height adjuster
3. Rear seat height adjuster
4. Low seat height position (rear shown)
5. High seat height position (rear shown)

GENERAL INFORMATION

To adjust the rider's seat:

- ▼ Remove the rider's seat (see page 98).
- ▼ Reposition both seat height adjusters to the higher or lower position as required.
- ▼ Make sure that both adjuster rails are fully engaged in their brackets on the seat.
- ▼ Reinstall the rider's seat making sure the seat tongue is under the upper bar on the fuel tank for the high seat position, or under the lower bar on the fuel tank for the low seat position, (see page 98).

Heated Seats (if equipped)

The heated seats switches (if equipped) are located on the left hand side of the motorcycle.

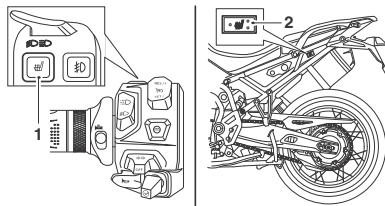

1. Rider's heated seat switch location

2. Passenger's heated seat switch location

The heated seats will only heat when the engine is running. When the heated seats are switched on, the heated seats symbol will appear in the display. The selected heat level for each seat will also be indicated by the color of the symbol.

GENERAL INFORMATION

There are two levels of heat: low and high.

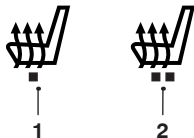

1. Low heat symbol (amber)
2. High heat symbol (red)

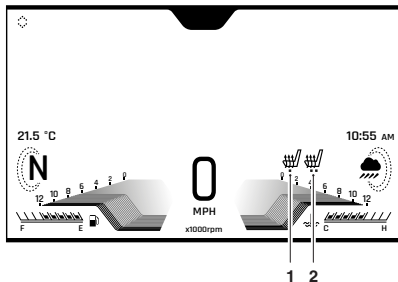

1. Rider's heated seat (low heat selected)
2. Passenger's heated seat (high heat selected)

Rider Heated Seat

- ▼ For maximum benefit in cold conditions, from the OFF position press the rider heated seat switch once for the high heat setting initially, and then reduce the heat level by pressing the rider heated seat switch again for the low heat setting when the seat has warmed up.
- ▼ To turn the rider heated seat off, press and release the rider heated seat switch until the heated seats symbol is no longer shown in the display.

Passenger Heated Seat

- ▼ For maximum benefit in cold conditions, switch the passenger heated seat switch to the high heat setting initially and then reduce the heat level by switching the passenger heated seat switch to the low heat setting when the passenger seat has warmed up.
- ▼ To turn the passenger heated seat off, move the switch to its central position. After a short delay, the passenger heated seat symbol will no longer be shown in the display.

Low Power Voltage Cut Off

If a low voltage is detected the heated seats switches will power off. The heated seats will not function again until the voltage rises to a safe level.

The switches will not power back on automatically even if the voltage rises to the safe level. The ignition must be switched off then on again to activate the heated seats.

GENERAL INFORMATION

Storage Compartment (if equipped)

Caution

Loose and unsecured items in the storage compartment may get damaged or cause damage to the motorcycle.

Make sure there is sufficient space surrounding any electronic devices or other items for the storage compartment to close without causing any damage to the items or the motorcycle.

Secure all electronic devices, cables and any other items safely in the storage compartment before riding.

Caution

Always make sure that the storage compartment lid is closed securely before reinstalling the seat to prevent damage to the storage compartment lid.

There is a small storage compartment located underneath the passenger seat. The storage compartment may be used to store electrical devices when using the USB socket, and small items when riding.

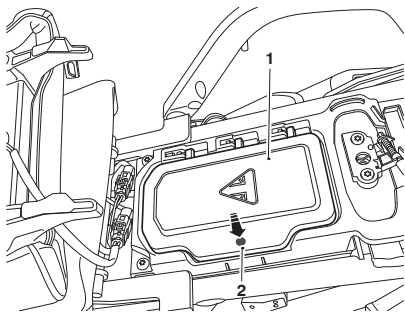

1. Storage compartment
2. Push to open

To open the storage compartment:

- ▼ Press the center of the left hand side of the storage compartment lid to release the lock device to open it.

Windshield

Warning

Never attempt to clean the windshield while riding the motorcycle.

Removal of the rider's hands from the handlebars while riding the motorcycle will diminish the ability of the rider to maintain the control of the motorcycle.

Attempting to clean the windshield while riding the motorcycle may result in loss of motorcycle control and an accident.

Warning

Make sure that the windshield is adjusted to the same position on both sides.

Riding the motorcycle with an incorrectly adjusted windshield could cause loss of motorcycle control and an accident.

The windshield installed on this motorcycle can be manually adjusted through five height positions without the use of tools.

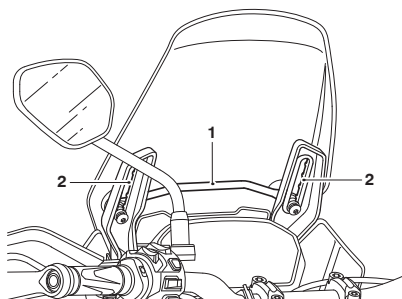

1. Height adjustment handle

2. Adjustment position

To adjust the windshield height:

- ▼ Safely sit on the motorcycle.
- ▼ Firmly grip the adjustment handle.
- ▼ Push the windshield forwards slightly to release the tension in the mountings.
- ▼ Slide the windshield up or down to the required height.
- ▼ Release the adjustment handle.

For windshield cleaning information, see page 194.

GENERAL INFORMATION

Tool Kit

Tiger 850 Sport

The tool kit is located under the passenger seat and is secured with a rubber strap.

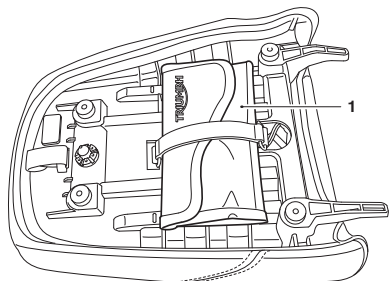

1. Tool kit

To access the tool kit, remove the passenger seat, see page 97.

All Models except Tiger 850 Sport

The tool kit is located in the storage tray under the rider's seat and is secured with a rubber strap.

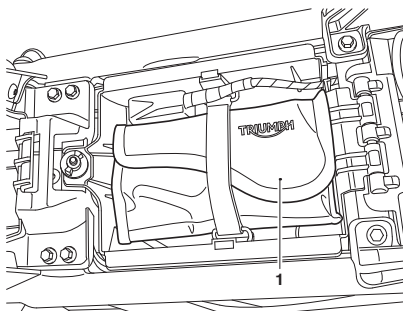

1. Tool kit

To access the tool kit, remove the passenger seat and then the rider's seat, see page 97 and page 98.

USB Socket (if equipped)

⚠ Warning

The USB socket is not waterproof unless the waterproof cap is installed. Do not connect electronic devices while it is raining.

Water in the USB socket could lead to an electrical problem, resulting in motorcycle damage, loss of motorcycle control and an accident.

⚠ Caution

Loose and unsecured items in the storage compartment may get damaged or cause damage to the motorcycle.

Make sure there is sufficient space surrounding any electronic devices or other items for the storage compartment to close without causing any damage to the items or the motorcycle.

Secure all electronic devices, cables and any other items safely in the storage compartment before riding.

⚠ Caution

Do not leave the ignition switch in the ON position unless the engine is running as this will discharge the battery.

The Universal Serial Bus (USB) socket allows a 5 Volt USB connection for charging electronic devices such as mobile phones, cameras and GPS devices. Loads up to two Amps can be connected to the USB socket.

To access the USB socket:

- ▼ Remove the passenger seat, see page 97.
- ▼ The USB socket is located in the storage compartment below the passenger seat.
- ▼ Press the center of the left hand side of the storage compartment lid to release the lock device to open it.

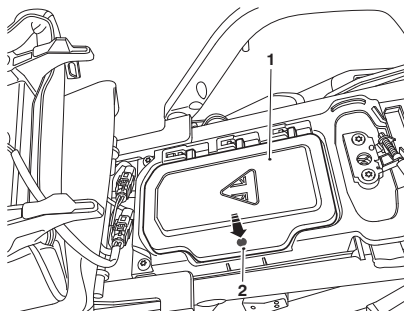

1. Storage compartment
2. Push to open

- ▼ Remove the cap.
- ▼ Plug the relevant USB adapter cable into the socket. Adapter cables are not supplied with the motorcycle.

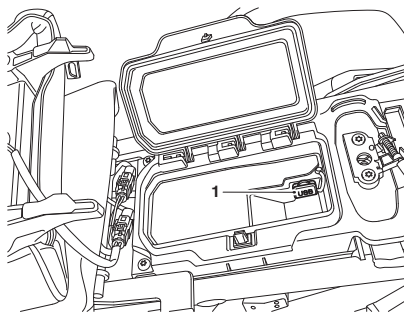

1. Universal Serial Bus (USB) socket

- ▼ Start the engine to access the power supply to the USB socket.

Electrical Accessory Sockets

Front Accessory Socket

All models have an accessory socket located next to the instrument display.

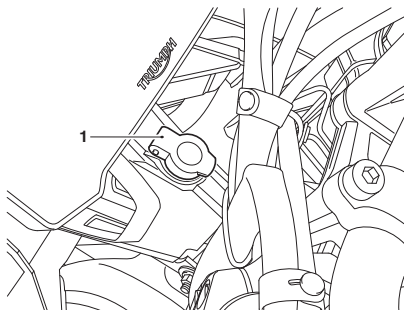

1. Accessory socket (front)

Rear Accessory Socket

All models except Tiger 850 Sport have an accessory socket located next to the seat lock.

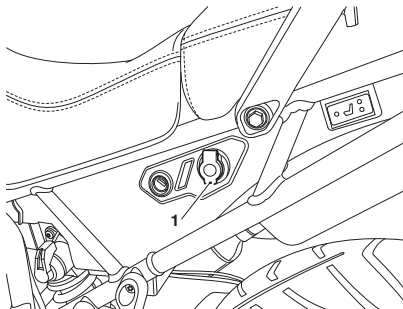

1. Accessory socket (rear)

The accessory sockets provide a 12 Volt electrical supply.

The accessory socket circuit is protected by the specified fuse shown in the fuse charts on page 179.

To protect the battery from excessive discharge while using mounted electrical accessories, the current which may be drawn through each electrical accessory sockets is five Amps.

A plug, suitable for use with the accessory sockets, is available from your authorized Triumph dealer.

Breaking-In



Breaking-in is the name given to the process that occurs during the first hours of a new vehicle's operation.

In particular, internal friction in the engine will be higher when components are new. Later on, when continued operation of the engine has ensured that the components have 'bedded in', this internal friction will be greatly reduced.

A period of careful breaking-in will ensure lower exhaust emissions, and will optimize performance, fuel economy and longevity of the engine and other motorcycle components.

During the first 600 miles (1,000 km):

- ▼ Do not use full throttle;
- ▼ Avoid high engine speeds at all times;
- ▼ Avoid riding at one constant engine speed, whether fast or slow, for a long period of time;
- ▼ Avoid aggressive starts, stops, and rapid accelerations, except in an emergency;
- ▼ Do not ride at speeds greater than 3/4 of maximum speed.

From 600 to 1,000 miles (1,000 to 1,500 km):

- ▼ Engine speed can gradually be increased to the rev limit for short periods.

Both during and after breaking-in has been completed:

- ▼ Do not overrev the engine when cold;
- ▼ Do not lug the engine. Always downshift before the engine begins to 'struggle';
- ▼ Do not ride with engine speeds unnecessarily high. Shifting up a gear helps reduce fuel consumption, reduces noise and helps to protect the environment.

GENERAL INFORMATION

Daily Safety Checks



Warning

Failure to perform these checks every day before you ride may result in serious motorcycle damage or an accident causing serious injury or death.

Check the following items each day before you ride. The time required is minimal, and these checks will help ensure a safe, reliable ride.

If any irregularities are found during these checks, refer to the Maintenance and Adjustment section or see your authorized Triumph dealer for the action required to return the motorcycle to a safe operating condition.

Check:

Fuel: Adequate supply in tank, no fuel leaks (see page 93).

Engine Oil: Correct level on dipstick or shown in sight glass. Add correct specification oil as required. No leaks from the engine or oil cooler (see page 136).

Drive Chain: Correct adjustment (see page 146).

Tires/Wheels: Correct inflation pressures (when cold). Tread depth/wear, tire/wheel damage, loose/broken spokes, punctures etc. (see page 169).

Nuts, Bolts, Fasteners: Visually check that steering and suspension components, axles, and all controls are properly tightened or fastened. Inspect all areas for loose/damaged fasteners.

Steering Action: Smooth but not loose from lock to lock. No binding of any of the control cables (see page 155).

Brakes: Pull the brake lever and push the brake pedal to check for correct resistance. Investigate any lever/pedal where the travel is excessive before meeting resistance, or if either control feels spongy in operation (see page 150).

Brake Pads: Check that the correct amount of friction material is remaining on all the brake pads (see page 150).

Brake Fluid Levels: No brake fluid leakage. Brake fluid levels must be between the MAX and MIN marks on both reservoirs (see page 151).

Front Forks: Smooth action. No fork oil leakage (see page 157).

Throttle: Make sure that the throttle grip returns to the idle position without sticking (see page 144).

Clutch: Smooth operation and correct cable free play (see page 145).

Coolant: No coolant leakage. Check the coolant level in the expansion tank (when the engine is cold) (see page 142).

Electrical Equipment: All lights and horn function correctly (see page 31).

Engine Stop: Engine start/stop switch turns the engine OFF when the switch is moved to the STOP position (see page 29).

Stands: Returns to the fully up position by spring tension. Return springs not weak or damaged (see page 94).

Table of Contents

Stopping the Engine.....	110
Starting the Engine.....	110
Moving Off	111
Shifting Gears	112
Triumph Shift Assist (TSA) (if equipped).....	113
Braking.....	114
Anti-lock Braking System (ABS).....	116
Optimized Cornering ABS (OCABS).....	117
Parking.....	119
Considerations for High Speed Operation	120

HOW TO RIDE THE MOTORCYCLE

Stopping the Engine

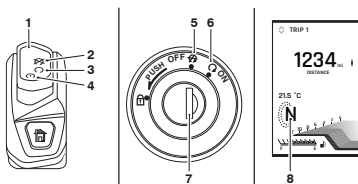

1. Engine stop switch
2. STOP position
3. RUN position
4. Starter button
5. OFF position
6. ON position
7. Ignition switch
8. Neutral indicator light

To stop the engine:

- ▼ Close the throttle completely.
- ▼ Select neutral.
- ▼ Turn the ignition switch OFF.
- ▼ Select first gear.
- ▼ Support the motorcycle on a firm, level surface with the side stand.
- ▼ Lock the steering.

⚠ Caution

The engine should not be stopped by turning the ignition switch to the OFF position when the motorcycle is moving. The engine stop switch is for emergency use only.

Stopping the engine when the motorcycle is moving may cause damage to motorcycle components.

Starting the Engine

⚠ Warning

Never start the engine or run the engine in a confined area.

Exhaust fumes are poisonous and can cause loss of consciousness and death within a short period of time.

Always operate the motorcycle in the open air or in an area with adequate ventilation.

⚠ Caution

Do not operate the starter continuously for more than five seconds as the starter motor will overheat and the battery will become discharged.

Wait 15 seconds between each operation of the starter to allow for cooling and recovery of battery power.

Do not let the engine idle for long periods as this may lead to overheating which will cause damage to the engine.

⚠ Caution

The low oil pressure warning light should go out shortly after the engine starts.

If the low oil pressure warning light stays on after starting the engine, stop the engine immediately and investigate the cause.

Running the engine with low oil pressure will cause severe engine damage.

To start the engine:

- ▼ Check that the engine stop switch is in the RUN position.
- ▼ Make sure that the transmission is in neutral.
- ▼ Turn the ignition switch ON.
- ▼ Pull the clutch lever fully into the handlebar.
- ▼ Leaving the throttle fully closed, push the starter button until the engine starts.

The motorcycle is equipped with starter lockout switches. The switches prevent the electric starter from operating when the transmission is not in neutral with the side stand down.

If the side stand is extended while the engine is running, and the transmission is not in neutral then the engine will stop regardless of clutch position.

Note

The instrument warning lights will illuminate and will then go off (except those which normally remain on until the engine starts, see page 42).

A transponder is installed within the key to turn off the engine immobilizer. To make sure that the immobilizer functions correctly, always have only one of the ignition keys near the ignition switch. Having two ignition keys near the switch may interrupt the signal between the transponder and the engine immobilizer. In this situation the engine immobilizer will remain active until one of the ignition keys is removed.

Moving Off

To move the motorcycle:

- ▼ Pull in the clutch lever and select first gear.
- ▼ Open the throttle a little and let out the clutch lever slowly.
- ▼ As the clutch starts to engage, open the throttle a little more, allowing enough engine speed to avoid stalling.

HOW TO RIDE THE MOTORCYCLE

Shifting Gears

Warning

Take care to avoid opening the throttle too far or too fast in any of the lower gears as this can lead to the front wheel lifting from the ground (pulling a 'wheelie') and to the rear tire breaking traction (wheel spin).

Always open the throttle cautiously, particularly if you are unfamiliar with the motorcycle, as a 'wheelie' or loss of traction will cause loss of motorcycle control and an accident.

Warning

Do not shift to a lower gear at speeds that will cause excessive engine rpm (r/min).

This can lock the rear wheel causing loss of control and an accident. Engine damage may also be caused.

Shifting down should be done such that low engine speeds will be ensured.

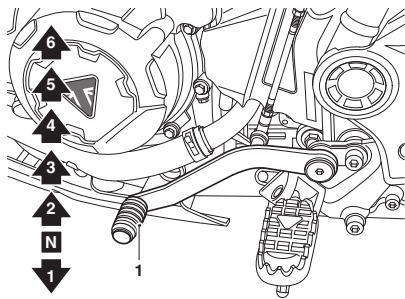

1. Gear shift pedal

To shift gears:

- ▼ Close the throttle while pulling in the clutch lever.
- ▼ Shift into the next higher or lower gear.
- ▼ Open the throttle part way, while releasing the clutch lever.
- ▼ Always use the clutch when shifting gear.

Note

The gear shift mechanism is the 'positive stop' type. This means that, for each movement of the gear shift pedal, you can only select each gear, one after the other, in ascending or descending order.

Triumph Shift Assist (TSA) (if equipped)

Caution

Triumph Shift Assist (TSA) is optimized for on-road use.

It must not be used during off-road riding.

Caution

In the event of a TSA system fault when riding, the TSA system will be disabled.

Use the clutch to shift gears in the normal way otherwise damage to the engine or gear box may occur.

Contact a Triumph dealer as soon as possible to have the fault checked and rectified.

Caution

Shifting gears must be completed with a quick and forceful pedal movement, making sure that the pedal moves through its full range of travel.

Always take care when shifting gears. After a gear shift, the pedal must be fully released before another gear shift can be made.

Incorrect gear shifts can cause damage to the engine and transmission.

Triumph Shift Assist (TSA) adjusts the engine torque to allow gears to engage, without closure of the throttle twist grip or operation of the clutch.

TSA is not an automatic system for shifting gears. Gears must be selected and shifted in the normal way using the gear pedal as described on page 112.

TSA works for both up shifts and down shifts of gear. The clutch must be used for stopping and pulling away. The clutch must be used when selecting any gear from neutral, and also when selecting neutral from any other gear.

Triumph Shift Assist will not operate if:

- ▼ The clutch is applied.
- ▼ An up shift is attempted by mistake when in 6th gear.
- ▼ A down shift is attempted by mistake when in 1st gear.
- ▼ An up shift is attempted at very low engine speeds.
- ▼ A down shift is attempted at very high engine speeds.
- ▼ An up shift is attempted during overrun.
- ▼ The vehicle speed limiter is active.
- ▼ Cruise control is active.
- ▼ Traction control is operating.
- ▼ If the previous gear has not fully engaged.
- ▼ The throttle is changed during a shift.

If TSA does not operate, the clutch can be used to shift gears in the normal way.

For more information on enabling and disabling the TSA functionality, see page 62.

HOW TO RIDE THE MOTORCYCLE

Braking

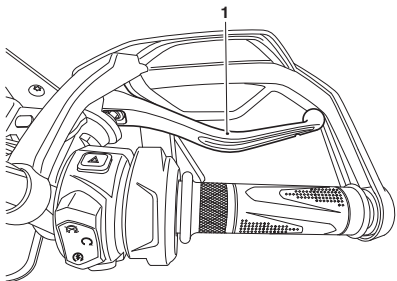

1. Front brake lever

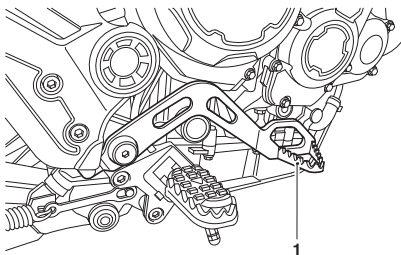

1. Rear brake pedal

Warning

WHEN BRAKING, OBSERVE THE FOLLOWING:

- Close the throttle completely, leaving the clutch engaged to allow the engine to help slow down the motorcycle.
- Shift down one gear at a time such that the transmission is in first gear when the motorcycle comes to a complete stop.
- When stopping, always apply both brakes at the same time. Normally the front brake should be applied a little more than the rear.
- Shift down or fully disengage the clutch as necessary to keep the engine from stalling.
- Never lock the brakes, as this may cause loss of control of the motorcycle and an accident.

Warning

For emergency braking, disregard down shifting, and concentrate on applying the front and rear brakes as hard as possible without skidding. Riders should practice emergency braking in a traffic-free area.

Triumph strongly recommends that all riders take a course of instruction, which includes advice on safe brake operation. Incorrect brake technique could result in loss of control and an accident.

Warning

For your safety, always exercise extreme caution when braking, accelerating or turning as any improper action can cause loss of control and an accident. Independent use of the front or rear brakes reduces overall braking performance. Extreme braking may cause either wheel to lock, reducing control of the motorcycle and causing an accident (see ABS warnings).

When possible, reduce speed or brake before entering a turn as closing the throttle or braking in mid-turn may cause wheel slip leading to loss of control and an accident.

When riding in wet or rainy conditions, or on loose surfaces, the ability to maneuver and stop will be reduced. All of your actions should be smooth under these conditions. Sudden acceleration, braking or turning may cause loss of control and an accident.

Warning

When descending a long, steep gradient or mountain pass, make use of the engine's braking effect by down shifting and use both front and rear brakes intermittently.

Continuous brake application or use of the rear brake only can overheat the brakes and reduce their effectiveness leading to loss of motorcycle control and an accident.

Warning

Riding with your foot on the brake pedal or your hands on the brake lever may actuate the brake light, giving a false indication to other road users.

It may also overheat the brake, reducing braking effectiveness leading to loss of motorcycle control and an accident.

Warning

Do not coast with the engine switched off, and do not tow the motorcycle.

The transmission is pressure lubricated only when the engine is running.

Inadequate lubrication may cause damage or seizure of the transmission, which can lead to sudden loss of motorcycle control and an accident.

Warning

When using the motorcycle on loose, wet, or muddy roads, braking effectiveness will be reduced by dust, mud or moisture collecting on the brakes.

Always brake earlier in these conditions to make sure that brake surfaces are cleaned by the braking action.

Riding the motorcycle with brakes contaminated with dust, mud or moisture may cause loss of motorcycle control and an accident.

HOW TO RIDE THE MOTORCYCLE

Anti-lock Braking System (ABS)

Warning

The ABS function attempts to maximize the chances of keeping the motorcycle under control when braking. The potentially shorter braking distances ABS allows under certain conditions are not a substitute for good riding practice.

Always ride within the legal speed limit.

Never ride without due care and attention and always reduce speed in consideration of weather, road and traffic conditions.

Take care when cornering. If the brakes are applied in a corner, ABS will not be able to counteract the weight and momentum of the motorcycle. This can result in loss of control and an accident.

Under some circumstances it is possible that a motorcycle equipped with ABS may require a longer stopping distance.

Warning

After riding off-road with ABS disabled, always make sure that the ABS is enabled when returning to ride on public roads.

Riding on public roads with the ABS disabled will, if braking too hard, cause the wheels to lock resulting in loss of motorcycle control and an accident.

Note

The ABS operation may feel like a harder pedal pressure or a pulsation of the brake lever and pedal.

The ABS is not an integrated braking system and does not control both the front and rear brake at the same time so this pulsation may be felt in the lever, the pedal or both.

The ABS may be activated by sudden upward or downward changes in the road surface.

ABS Warning Light



When the ignition switch is turned to the ON position, it is normal for the ABS warning light to flash on and off (see page 44). If the ABS warning light is constantly illuminated it indicates that the ABS function is not available because:

- ▼ The ABS has been disabled by the rider.
- ▼ The ABS has a malfunction that requires investigation.

If the indicator light becomes illuminated while riding, it indicates that the ABS has a malfunction that requires investigation.

Optimized Cornering ABS (OCABS) (if equipped)

The warning light will flash slowly if Optimized Cornering ABS (OCABS) is switched off by the OFF-ROAD or OFF-ROAD PRO riding modes. A warning message will be shown in the instrument display.

 **Warning**

If the ABS is not functioning, the brake system will continue to function as a non-ABS equipped brake system.

Do not continue to ride for longer than is necessary with the warning light illuminated.

Contact an authorized Triumph dealer as soon as possible to have the fault checked and rectified. In this situation braking too hard will cause the wheels to lock resulting in loss of motorcycle control and an accident.

 **Warning**

The ABS warning light will illuminate when the rear wheel is driven at high speed for more than 30 seconds when the motorcycle is on a stand. This reaction is normal.

When the ignition is switched off and the motorcycle is restarted, the warning light will illuminate until the motorcycle reaches a speed exceeding 19 mph (30 km/h).

 **Warning**

ABS operates by comparing the relative speed of the front and rear wheels.

Use of non-recommended tires can affect wheel speed and cause the ABS not to operate, potentially leading to loss of control and an accident in conditions where the ABS would normally function.

Optimized Cornering ABS (OCABS)

Note

Only on Tiger 900 GT, Tiger 900 GT Pro, Tiger 900 Rally, Tiger 900 Rally Pro and Tiger 900 Bond Edition models.

The optimized cornering ABS is a system designed to give the rider increased control should the ABS be activated while the motorcycle is leaning in a corner.

A sensor constantly monitors the lean angle of the motorcycle. If the motorcycle is leaning in a corner and the ABS is activated, the system will use the lean angle measurement to apply the ABS in a manner most suitable to help the rider maintain motorcycle control.

 **Warning**

The optimized cornering ABS is a system designed to help the rider in emergency braking situations.

The system is designed to give the rider increased control should the ABS be activated while the motorcycle is leaning in a corner.

The potential increased control that the optimized cornering braking system allows under certain conditions is not a substitute for good riding practice.

HOW TO RIDE THE MOTORCYCLE

Warning

Always ride within the legal speed limit. Never ride without due care and attention and always reduce speed in consideration of weather, surface and traffic conditions. Take care when cornering.

If the motorcycle is leaning in a corner and the ABS is activated, the optimized cornering ABS will use the lean angle measurement from a sensor to apply the ABS to assist the rider to maintain motorcycle control. The optimized cornering ABS will not however be able to fully counteract the weight and momentum of the motorcycle and braking too hard while cornering may result in loss of motorcycle control and an accident.

Under some circumstances it is possible that a motorcycle equipped with optimized cornering ABS may require a longer stopping distance than an equivalent motorcycle without ABS, or an equivalent motorcycle equipped with ABS but not equipped with optimized cornering ABS.

Warning

If the optimized cornering ABS is not functioning, the ABS warning light will illuminate and a warning message is shown in the display.

In this situation, the ABS will continue to operate but without the optimized cornering function, provided that:

- There are no other ABS faults.
- The ABS has not been disabled by the rider.

Do not continue to ride for longer than is necessary with the warning light illuminated. In the event of a fault, contact an authorized Triumph dealer as soon as possible to have the fault checked and rectified.

In this situation, braking too hard during cornering may result in loss of motorcycle control and an accident.

Note

Optimized Cornering ABS (OCABS) is disabled in the OFF-ROAD riding mode or if the ABS is switched off, and can be disabled in the OFF-ROAD PRO riding mode.

Parking

Warning

Gasoline is extremely flammable and can be explosive under certain conditions.

If parking inside a garage or other structure, be sure it is well ventilated and the motorcycle is not close to any source of flame or sparks. This includes any appliance with a pilot light.

Failure to follow the above advice may cause a fire resulting in damage to property or personal injury.

Warning

The engine and exhaust system will be hot after riding.

DO NOT park where pedestrians and children are likely to touch the motorcycle.

Touching any part of the engine or exhaust system when hot may cause unprotected skin to become burnt.

Warning

Do not park on a soft or steeply inclined surface.

Parking under these conditions may cause the motorcycle to fall over causing damage to property and personal injury.

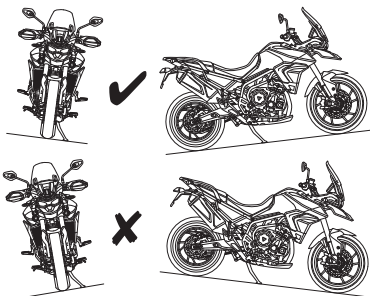

To park the motorcycle:

- ▼ Select neutral and turn the ignition switch to the OFF position.
- ▼ Lock the steering to help prevent theft.
- ▼ Always park on a firm, level surface to prevent the motorcycle from falling. This is particularly important when parking off-road.
- ▼ When parking on a hill, always park facing uphill to prevent the motorcycle from rolling off the stand. Engage first gear to prevent the motorcycle from moving.
- ▼ On a lateral (sideways) incline, always park such that the incline naturally pushes the motorcycle towards the side stand.
- ▼ Do not park on a lateral (sideways) incline of greater than 6° and never park facing downhill.

HOW TO RIDE THE MOTORCYCLE

Considerations for High Speed Operation

Warning

This Triumph motorcycle should be operated within the legal speed limits for the particular road traveled.

Operating a motorcycle at high speeds can be potentially dangerous since the time available to react to given traffic situations is greatly reduced as road speed increases.

Always reduce speed in potentially hazardous driving conditions such as bad weather or heavy traffic.

Warning

Only operate this Triumph motorcycle at high speed in closed-course, on-road competition or on closed-course racetracks.

High speed operation should only then be attempted by riders who have been instructed in the techniques necessary for high speed riding and are familiar with the motorcycle's characteristics in all conditions.

High speed operation in any other circumstances is dangerous and will lead to loss of motorcycle control and an accident.

Warning

The handling characteristics of a motorcycle at high speed may vary from those you are familiar with at legal road speeds.

Do not attempt high speed operation unless you have received sufficient training and have the required skills as a serious accident may result from incorrect operation.

Warning

The items listed below are extremely important and must never be neglected. A problem, which may not be noticed at normal operating speeds, may be greatly exaggerated at high speeds.

General

Make sure that the motorcycle has been maintained according to the scheduled maintenance chart.

Brakes

Check that the front and rear brakes are functioning correctly.

Coolant

Check that the coolant level is at the upper level line in the expansion tank. Always check the level with the engine cold.

Electrical Equipment

Make sure that all electrical equipment such as the headlight, rear/brake light, turn signals and horn all work correctly.

Engine Oil

Check that the engine oil level is correct. Make sure that the correct grade and type of oil is used when topping off.

Drive Chain

Make sure that the drive chain is correctly adjusted and lubricated. Inspect the chain for wear and damage.

Fuel

Have sufficient fuel for the increased fuel consumption that will result from high speed operation.



Caution

In many countries, the exhaust system for this model is equipped with a catalytic converter to help reduce exhaust emission levels.

The catalytic converter can be permanently damaged if the motorcycle is allowed to run out of fuel or if the fuel level is allowed to get very low.

Always make sure you have adequate fuel for your trip.

Luggage

Make sure that any luggage containers are closed, locked and securely installed on the motorcycle.

Miscellaneous

Visually check that all fasteners are tight.

Steering

Check that the handlebar turns smoothly without excessive free play or tight spots. Make sure that the control cables do not restrict the steering in any way.

Tires

High speed operation is hard on tires, and tires that are in good condition are crucial to riding safely. Examine their overall condition, inflate to the correct pressure (when the tires are cold), and check the wheel balance. Securely install the valve caps after checking tire pressures. Observe the information given in the maintenance and specification sections on tire checking and tire safety.

This page intentionally left blank

The addition of accessories and carrying of additional weight can affect the motorcycle's handling characteristics causing changes in stability and necessitating a reduction in speed. The following information has been prepared as a guide to the potential hazards of adding accessories to a motorcycle and carrying passengers and additional loads.

Accessories

Warning

Do not install accessories or carry luggage that impairs the control of the motorcycle.

Make sure that you have not adversely affected any lighting component, road clearance, banking capability (i.e. lean angle), control operation, wheel travel, front fork movement, visibility in any direction, or any other aspect of the motorcycle's operation.

Warning

Owners should be aware that the only approved parts, accessories and conversions for any Triumph motorcycle are those which carry official Triumph approval and are installed to the motorcycle by an authorized dealer.

In particular, it is extremely hazardous to install or replace parts or accessories whose installation requires the dismantling of, or addition to, either the electrical or fuel systems and any such modification could cause a safety hazard.

The installation of any non-approved parts, accessories or conversions may adversely affect the handling, stability or other aspect of the motorcycle operation that may result in an accident causing injury or death.

Triumph does not accept any liability whatsoever for defects caused by the installation of non-approved parts, accessories or conversions or the installation of any approved parts, accessories or conversions by non-approved personnel.

ACCESSORIES, LOADING AND PASSENGERS

Warning

Install only genuine Triumph accessories to the correct Triumph motorcycle model.

Always check the Triumph Fitting Instruction associated with the genuine Triumph accessory. Make sure the Triumph motorcycle model that the Triumph accessory is to be installed on, is listed as approved for the genuine Triumph accessory. For all Triumph Fitting Instructions, see www.triumphinstructions.com.

Never install genuine Triumph accessories to a Triumph motorcycle model that is not listed in the associated Triumph Fitting Instruction, as this may affect handling, stability or other aspects of the motorcycle operation that may result in an accident causing severe injuries or death.

Warning

Never ride an accessory equipped motorcycle, or a motorcycle carrying a payload of any kind, at speeds above 80 mph (130 km/h). In either/both of these conditions, speeds in excess of 80 mph (130 km/h) should not be attempted even where the legal speed limit permits this.

The presence of accessories and/or payload will cause changes in the stability and handling of the motorcycle.

Failure to allow for changes in motorcycle stability may lead to loss of motorcycle control and an accident. When riding at high speed, always be aware that various motorcycle configuration and environmental factors can adversely affect the stability of your motorcycle. For example:

- Incorrectly balanced loads on both sides of the motorcycle
- Incorrectly adjusted front and rear suspension settings
- Incorrectly adjusted tire pressures
- Excessively or unevenly worn tires
- Side winds and turbulence from other vehicles
- Loose clothing.

Remember that the 80 mph (130 km/h) absolute limit will be reduced by the installation of non-approved accessories, incorrect loading, worn tires, overall motorcycle condition and poor road or weather conditions.

Loading

 **Warning**

Always make sure that any loads carried are evenly distributed on both sides of the motorcycle. Make sure that the load is correctly secured so that it will not move around while the motorcycle is in motion.

Evenly distribute the load within each pannier (if equipped). Pack heavy items at the bottom and on the inboard side of the pannier.

Always check the load security regularly (though not while the motorcycle is in motion) and make sure that the load does not extend beyond the rear of the motorcycle.

Never exceed the maximum vehicle loading weight as specified in the Specifications section.

This maximum loading weight is made up from the combined weight of the rider, passenger, any accessories installed and any load carried.

For models that have adjustable suspension settings, make sure that front and rear spring preload and damping settings are suitable for the loading condition of the motorcycle. Note the maximum permissible payload for the panniers is stated on a label inside the pannier.

Incorrect loading may result in an unsafe riding condition leading to an accident.

 **Warning**

The maximum safe load for each pannier is stated on a label inside the pannier.

Never exceed this loading limit as this may cause the motorcycle to become unstable leading to loss of motorcycle control and an accident.

 **Warning**

Never attempt to store any items between the frame and the fuel tank.

This can restrict the steering and will cause loss of control leading to an accident.

Weight attached to the handlebar or front fork will increase the mass of the steering assembly and can result in loss of steering control leading to an accident.

 **Warning**

If the passenger seat is used to carry small objects, they must not exceed 11 lb (5 kg) in weight, must not impair control of the motorcycle, must be securely attached and must not extend beyond the rear or sides of the motorcycle.

Carrying objects in excess of 11 lb (5 kg) in weight, that are insecure, impair control or extend beyond the rear or sides of the motorcycle may lead to loss of motorcycle control and an accident.

Even if small objects are correctly loaded onto the passenger seat, the maximum speed of the motorcycle must be reduced to 80 mph (130 km/h).

ACCESSORIES, LOADING AND PASSENGERS

Passengers

Warning

The handling and braking capabilities of a motorcycle will be affected by the presence of a passenger.

The rider must make allowances for these changes when operating the motorcycle with a passenger and should not attempt such operation unless trained to do so and without becoming familiar and comfortable with the changes in motorcycle operating characteristics that this brings about.

Motorcycle operation without making allowances for the presence of a passenger could lead to loss of motorcycle control and an accident.

Warning

Do not carry a passenger unless they are tall enough to reach the footrests provided.

A passenger who is not tall enough to reach the footrests will be unable to sit securely on the motorcycle and may cause instability leading to loss of control and an accident.

Warning

Your passenger should be instructed that they can cause loss of motorcycle control by making sudden movements or by adopting an incorrect seated position.

The rider should instruct the passenger as follows:

- It is important that the passenger sits still while the motorcycle is in motion and does not interfere with the operation of the motorcycle.
- To keep their feet on the passenger footrests and to firmly hold onto the seat strap or the rider's waist or hips.
- Advise the passenger to lean with the rider when traveling around corners and not to lean unless the rider does so.

Warning

The handling and braking capabilities of a motorcycle will be affected by the presence of a passenger.

The rider must make allowances for these changes when operating the motorcycle with a passenger and should not attempt such operation unless trained to do so and without becoming familiar and comfortable with the changes in motorcycle operating characteristics that this brings about.

Motorcycle operation without making allowances for the presence of a passenger could lead to loss of motorcycle control and an accident.

Warning

Do not carry animals on your motorcycle.

An animal could make sudden and unpredictable movements that could lead to loss of motorcycle control and an accident.

This page intentionally left blank

Table of Contents

Scheduled Maintenance.....	131
Scheduled Maintenance Table.....	133
Engine Oil.....	136
Sump Guard.....	136
Engine Oil Level Inspection.....	137
Engine Oil and Oil Filter Change.....	138
Disposal of Used Engine Oil and Oil Filters.....	140
Engine Oil Specification and Grade (10W/40 & 10W/50).....	140
Cooling System.....	141
Coolant Level Inspection.....	142
Coolant Level Adjustment.....	143
Coolant Change.....	144
Throttle Control.....	144
Clutch.....	145
Clutch Inspection.....	145
Clutch Adjustment.....	145
Drive Chain.....	146
Drive Chain Lubrication.....	146
Drive Chain Free Movement Inspection.....	147
Drive Chain and Sprocket Wear Inspection.....	149
Brakes.....	150
Breaking-in New Brake Pads and Discs.....	150
Brake Pad Wear Compensation.....	151
Disc Brake Fluid.....	151
Front Brake Fluid Level Inspection and Adjustment.....	152
Rear Brake Fluid Level Inspection and Adjustment.....	154
Brake Light Switches.....	154
Steering Inspection.....	155
Front Suspension.....	157
Front Suspension Setting Charts.....	157
Front Suspension Spring Preload Adjustment.....	159
Front Suspension Compression Damping Adjustment.....	160
Front Suspension Compression Damping Adjustment.....	160
Front Suspension Rebound Damping Adjustment.....	161
Front Suspension Rebound Damping Adjustment.....	161
Front Fork Inspection.....	162

MAINTENANCE

- Rear Suspension..... 163
 - Rear Suspension Setting Charts 163
 - Rear Suspension Spring Preload Adjustment 166
 - Rear Suspension Spring Preload Adjustment 166
 - Rear Suspension Rebound Damping Adjustment 167
 - Rear Suspension Rebound Damping Adjustment 167
- Bank Angle Indicators 168
- Tires 169
 - Tire Inflation Pressures 170
 - Tire Pressure Monitoring System (TPMS) (if equipped)..... 170
 - Tire Wear 171
 - Minimum Recommended Tread Depth..... 171
 - Tire Replacement 172
- Battery 174
 - Battery Removal..... 174
 - Battery Disposal 175
 - Battery Maintenance 175
 - Battery Discharge..... 176
 - Battery Discharge During Storage and Infrequent Use of the Motorcycle 176
 - Battery Charging..... 177
 - Battery Installation..... 178
- Fuses 179
 - Fuse Identification 180
 - Fuse Identification 181
 - Fuse Identification 182
- Headlights..... 183
 - Headlights Adjustment 184
 - Headlights Replacement..... 184
 - Daytime Running Light (DRL) (if equipped) 184
- Lights 185
 - Turn Signal Lights..... 185
 - Tail/Brake Light / License Plate Light 185
 - Fog Lights (if equipped)..... 185
- Mirrors..... 186

Scheduled Maintenance

Warning

Triumph Motorcycles cannot accept any responsibility for damage or injury resulting from incorrect maintenance or improper adjustment carried out by the owner.

Incorrect or neglected maintenance can lead to a dangerous riding condition.

Always have an authorized Triumph dealer carry out the scheduled maintenance of this motorcycle.

Warning

All maintenance is vitally important and must not be neglected. Incorrect maintenance or adjustment may cause one or more parts of the motorcycle to malfunction. A malfunctioning motorcycle may lead to loss of control and an accident.

Weather, terrain and geographical location affect maintenance. The maintenance schedule should be adjusted to match the particular environment in which the motorcycle is used and the demands of the individual owner.

Special tools, knowledge and training are required in order to correctly carry out the maintenance items listed in the scheduled maintenance chart. Only an authorized Triumph dealer will have this knowledge and equipment.

Incorrect or neglected maintenance can lead to a dangerous riding condition. Always have an authorized Triumph dealer carry out the scheduled maintenance of this motorcycle.

To maintain the motorcycle in a safe and reliable condition, the maintenance and adjustments outlined in this section must be carried out as specified in the schedule of daily checks, and also in line with the scheduled maintenance chart. The information that follows describes the procedures to follow when carrying out the daily checks and some simple maintenance and adjustment items.

MAINTENANCE

Scheduled maintenance may be carried out by your authorized Triumph dealer in three ways; annual maintenance, mileage based maintenance or a combination of both, depending on the mileage the motorcycle travels each year.

1. Motorcycles traveling less than 6,000 miles (10,000 km) per year must be maintained annually. In addition to this, mileage based items require maintenance at their specified intervals, as the motorcycle reaches this mileage.
2. Motorcycles traveling approximately 6,000 miles (10,000 km) per year must have the annual maintenance and the specified mileage based items carried out together.
3. Motorcycles traveling more than 6,000 miles (10,000 km) per year must have the mileage based items maintained as the motorcycle reaches the specified mileage. In addition to this, annual based items will require maintenance at their specified annual intervals.

In all cases maintenance must be carried out at or before the specified maintenance intervals shown. Consult an authorized Triumph dealer for advice on which maintenance schedule is most suitable for your motorcycle.

Triumph Motorcycles cannot accept any responsibility for damage or injury resulting from incorrect maintenance or improper adjustment.

Service Symbol/General Warning Symbol



The service symbol will illuminate for five seconds after the motorcycle start up sequence as a reminder that a service is due in approximately 60 miles (100 km). The service symbol will illuminate permanently when the mileage is reached, it will remain permanently illuminated until the service interval is reset using the Triumph Diagnostic tool.



The general warning symbol will flash if an ABS or engine management fault has occurred and the ABS and/or MIL warning lights are illuminated. Contact an authorized Triumph dealer as soon as possible to have the fault checked and rectified.

Note

Items marked * in the following table are subject to additional labor charge, above the cost and time allowance for the basic service, which includes time to check only.

Scheduled Maintenance Table

Operation description	Odometer Reading in Miles (km) or Time Period, whichever comes first					
		First Service	Annual Service	Mileage Based Service		
	Daily	600 Mile/6 Month Service	Year	6,000 and 18,000 Mile (10,000 and 30,000 Km) Service	12,000 Mile (20,000 Km) Service	24,000 Mile (40,000 Km) Service
Lubrication						
Engine and oil cooler - check for leaks	•	•	•	•	•	•
Engine oil - replace		•	•	•	•	•
Engine oil filter - replace		•	•	•	•	•
Fuel System and Engine Management						
Fuel system - check for leaks	•					
Fuel system - check fuel hoses for chafing, cracks or damage. Replace if necessary		•	•	•	•	•
Autoscan - carry out a full Autoscan using the Triumph diagnostic tool (print a customer copy)		•	•	•	•	•
Throttle bodies/carburetors - balance*				•	•	•
Throttle body plate (butterfly) - check/clean					•	•
Secondary air injection system - check/clean					•	•
Air filter - replace					•	•
Spark plugs - replace					•	•
Cooling System						
Cooling system - check for leaks	•	•	•	•	•	•
Coolant level - check/adjust	•	•	•	•	•	•
Coolant - replace - every 3 years, regardless of mileage*		Every three years, regardless of mileage				
Engine						
Clutch - check operation	•					
Clutch cable - check function and adjust as necessary (models equipped with a cable clutch only)	•	•	•	•	•	•
Valve clearances - check/adjust*					•	•
Camshaft timing - check/adjust*					•	
Wheels and Tires						
Wheels - inspect for damage	•	•	•	•	•	•
Wheels - check for broken or damaged spokes and check spoke tightness (not alloy wheels)	•	•	•	•	•	•
Tire wear/tire damage - check	•	•	•	•	•	•
Tire pressures - check/adjust	•	•	•	•	•	•
Wheel bearings - check for wear/smooth operation		•	•	•	•	•

Operation description	Odometer Reading in Miles (km) or Time Period, whichever comes first					
		First Service	Annual Service	Mileage Based Service		
	Daily	600 Mile/6 Month Service	Year	6,000 and 18,000 Mile (10,000 and 30,000 Km) Service	12,000 Mile (20,000 Km) Service	24,000 Mile (40,000 Km) Service
Steering and Suspension						
Steering - check for free operation	•	•	•	•	•	•
Front and rear suspension - check for damage/leaks/smooth operation	•	•	•	•	•	•
Steering head bearings - check/adjust - except first service			•	•	•	•
Steering head bearings - lubricate					•	•
Rear suspension unit and linkage - lubricate (single rear suspension unit models only)					•	•
Fork oil - replace						•
Brakes						
Brake system - check operation	•					
Brake pads - check wear levels*	•	•	•	•	•	•
Brake fluid levels - check	•	•	•	•	•	•
Brake master cylinders - check for fluid leaks		•	•	•	•	•
Brake calipers - check for fluid leaks and seized pistons*		•	•	•	•	•
Brake fluid - replace - every 2 years, regardless of mileage*		Every two years, regardless of mileage				
Final Drive						
Drive chain slack - check/adjust	•	•	•	•	•	•
Drive chain rubbing strip - check for wear, cracks or damage*	•		•			
Drive chain - lubricate		•	•	•	•	•
Drive chain - wear check*			•	•	•	•
Drive chain rubbing strip - replace*				•	•	•
Electrical						
Lights, instruments and electrical systems - check/adjust	•	•	•	•	•	•
ABS Modulator - Check for stored DTCs		•	•	•	•	•

Operation description	Odometer Reading in Miles (km) or Time Period, whichever comes first					
		First Service	Annual Service	Mileage Based Service		
	Daily	600 Mile/6 Month Service	Year	6,000 and 18,000 Mile (10,000 and 30,000 Km) Service	12,000 Mile (20,000 Km) Service	24,000 Mile (40,000 Km) Service
General						
Bank angle indicators - check for wear*	•	•	•	•	•	•
Center and/or side stand - check for wear/smooth operation	•	•	•	•	•	•
Instruments, chassis ECM, engine ECM and suspension ECM - check for latest calibration download using the Triumph diagnostic tool		•	•	•	•	•
Fasteners - inspect visually for security		•	•	•	•	•
Carry out all outstanding Service Bulletin and warranty work		•	•	•	•	•
Carry out road test		•	•	•	•	•
Complete the service record book and reset the service indicator (if equipped)		•	•	•	•	•
Accessory rack sliding carriage - check for correct operation*			•	•	•	•
Center stand flanged sleeves (if equipped) - clean/grease			•	•	•	•
Accessory pannier link mechanism - check for correct operation and adjustment*			•	•	•	•
Side stand pivot pin - clean/grease				•	•	•

Engine Oil



Warning

Motorcycle operation with insufficient, deteriorated, or contaminated engine oil will cause accelerated engine wear and may result in engine or transmission seizure.

Seizure of the engine or transmission may lead to sudden loss of motorcycle control and an accident.

In order for the engine, transmission, and clutch to function correctly, maintain the engine oil at the correct level, and change the engine oil and oil filter in accordance with scheduled maintenance requirements.

Sump Guard

The sump guard must be removed to allow access to change the engine oil and oil filter.

Tiger 900 Rally Pro Only

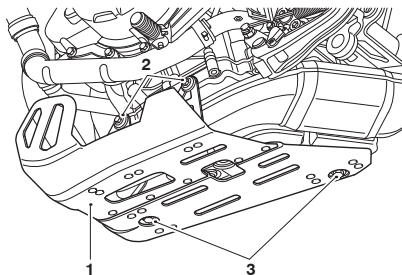

1. Sump guard
2. Left hand side fixings
3. Bottom fixings

To remove the sump guard:

- ▼ Remove the two left hand side fixings. Note the orientation of the flanged sleeve for installation.
- ▼ Remove the two bottom fixings and remove the sump guard.

To reinstall the sump guard:

- ▼ Align the sump guard to the motorcycle and secure with the two bottom fixings. Do not fully tighten at this stage.
- ▼ Reinstall the two left hand side fixings and tighten to 53 lbf in (6 Nm).
- ▼ Tighten the bottom fixings to 53 lbf in (6 Nm).

All Models except Tiger 900 Rally Pro

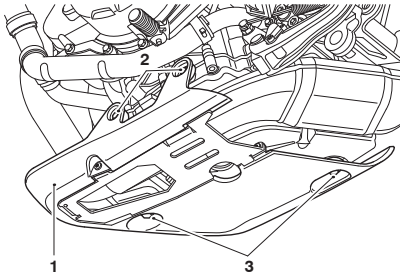

1. Sump guard
2. Left hand side fixings
3. Bottom fixings

To remove the sump guard:

- ▼ Remove the two left hand side fixings.
- ▼ Remove the two bottom fixings and remove the sump guard.

To reinstall the sump guard:

- ▼ Align the sump guard to the motorcycle and secure with the two bottom fixings. Do not fully tighten at this stage.
- ▼ Reinstall the two left hand side fixings and tighten to 53 lbf in (6 Nm).
- ▼ Tighten the bottom fixings to 53 lbf in (6 Nm).

Engine Oil Level Inspection

! Warning

Never start the engine or run the engine in a confined area.

Exhaust fumes are poisonous and can cause loss of consciousness and death within a short period of time.

Always operate the motorcycle in the open air or in an area with adequate ventilation.

! Warning

If the engine has recently been running, the exhaust components may be hot to the touch.

Contact with the hot components may cause damage to exposed skin.

To avoid skin damage, always allow the hot parts to cool before touching the exhaust system.

! Caution

Running the engine with insufficient engine oil will cause engine damage.

If the low oil pressure indicator remains on, stop the engine immediately and investigate the situation.

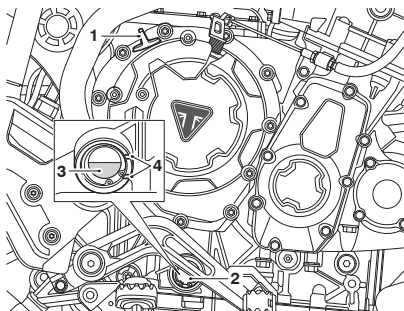

1. Filler
2. Sight glass
3. Engine oil level (correct level shown)
4. Crankcase engine oil level lines

To inspect the engine oil level:

- ▼ Start the engine and run at idle for approximately five minutes.
- ▼ Stop the engine, then wait for at least three minutes for the engine oil to settle.
- ▼ Note the engine oil level visible in the sight glass.
- ▼ When correct, engine oil should be visible in the sight glass at a point midway between the upper (maximum) and lower (minimum) horizontal lines marked on the crankcase.

Note

An accurate indication of the level of engine oil in the engine is only shown when the engine is at normal operating temperature and the motorcycle is upright (not on the side stand).

- ▼ If it is necessary to top off the engine oil level, remove the filler plug and add engine oil, a little at a time, until the level registered in the sight glass is correct.
- ▼ Once the correct level is reached, install and tighten the filler plug.

Engine Oil and Oil Filter Change

⚠ Warning

Prolonged or repeated contact with engine oil can lead to skin dryness, irritation and dermatitis.

Used engine oil contains harmful contamination that can lead to skin cancer.

Always wear suitable protective clothing and avoid skin contact with used engine oil.

⚠ Warning

The engine oil may be hot.

Avoid contact with the hot engine oil by wearing suitable protective clothing, gloves and eye protection.

Contact with hot engine oil may cause the skin to be scalded or burned.

The engine oil and filter must be replaced in accordance with scheduled maintenance requirements.

Note

The sump guard must be removed before starting this procedure, see page 136.

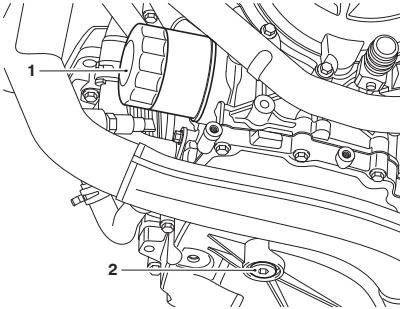

1. Engine oil filter
2. Engine oil drain plug

To change the engine oil and engine oil filter:

- ▼ Warm up the engine thoroughly, and then stop the engine and secure the motorcycle in an upright position on level ground.
- ▼ Place an oil drain pan beneath the engine.
- ▼ Remove the engine oil drain plug.
- ▼ Unscrew and remove the engine oil filter using Triumph service tool T3880313. Dispose of the old engine oil filter in an environmentally friendly way.
- ▼ Apply a thin smear of clean engine oil to the sealing ring of the new engine oil filter. Install the engine oil filter and tighten to 89 lbf in (10 Nm).
- ▼ After the engine oil has completely drained out, install a new sealing washer to the drain plug. Install and tighten the drain plug to 18 lbf ft (25 Nm).

- ▼ Fill the engine with a 10W/40 or 10W/50 semi or fully synthetic motorcycle engine oil that meets specification API SH (or higher) and JASO MA, such as Castrol Power 1 Racing 4T 10W-40 (fully synthetic).
- ▼ Start the engine and allow it to idle for a minimum of 30 seconds.

⚠ Caution

Raising the engine speed above idle before the oil reaches all parts of the engine can cause engine damage or seizure.

Only raise engine speed after running the engine for 60 seconds to allow the engine oil to circulate fully.

⚠ Caution

If the engine oil pressure is too low, the low oil pressure warning light will illuminate. If this light stays on when the engine is running, stop the engine immediately and investigate the cause.

Running the engine with low oil pressure will cause engine damage.

- ▼ Make sure that the low oil pressure warning light remains off and the engine oil pressure message is not shown in the instrument display screen.
- ▼ Stop the engine and recheck the oil level. Adjust if necessary.

Disposal of Used Engine Oil and Oil Filters

To protect the environment, do not pour oil on the ground, down sewers or drains, or into groundwater sources.

Do not place used oil filters in with general waste. If in doubt, contact your local authority.

Engine Oil Specification and Grade (10W/40 & 10W/50)

Triumph's high performance fuel injected engines are designed to use 10W/40 or 10W/50 semi or fully synthetic motorcycle engine oil that meets specification API SH (or higher) and JASO MA, such as Castrol Power 1 Racing 4T 10W-40 (fully synthetic) engine oil, sold as Castrol Power RS Racing 4T 10W-40 (fully synthetic) in some countries.

Refer to the chart below for the correct oil viscosity (10W/40 or 10W/50) to be used in your riding area.

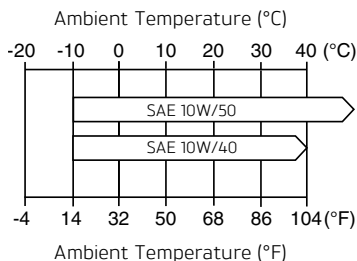

Oil Viscosity Temperature Range

Do not add any chemical additives to the engine oil. The engine oil also lubricates the clutch and any additives could cause the clutch to slip.

Do not use mineral, vegetable, non-detergent oil, castor based oils or any oil not conforming to the required specification. The use of these oils may cause instant, severe engine damage.

Make sure that no foreign matter enters the crankcase during an engine oil change or top off.

Cooling System



To ensure efficient engine cooling, check the coolant level each day before riding the motorcycle, and top off the coolant if the level is low.

Note

A year round, Hybrid Organic Acid Technology (known as Hybrid OAT or HOAT) coolant is installed in the cooling system when the motorcycle leaves the factory. It is colored green, contains a 50% solution of ethylene glycol based antifreeze, and has a freezing point of -31°F (-35°C).

Corrosion Inhibitors

Warning

HD4X Hybrid OAT coolant contains corrosion inhibitors and antifreeze suitable for aluminum engines and radiators. Always use the coolant in accordance with the instructions of the manufacturer.

Coolant contains toxic chemicals that are harmful to the human body.

Contact with skin or eyes may cause severe irritation. Wear protective gloves, clothing and eye protection when handling coolant.

If coolant is inhaled, remove the person to fresh air and keep comfortable for breathing. In case of doubt or persistent symptoms, seek medical attention.

If coolant gets on your skin, flush with water immediately. Remove contaminated clothing.

If coolant gets in your eyes, flush with water for at least 15 minutes and SEEK MEDICAL ATTENTION IMMEDIATELY.

If coolant is swallowed, rinse the mouth with water and SEEK MEDICAL ATTENTION IMMEDIATELY.

KEEP COOLANT OUT OF THE REACH OF CHILDREN.

Note

HD4X Hybrid OAT coolant, as supplied by Triumph, is premixed and does not need to be diluted prior to filling or topping off the cooling system.

To protect the cooling system from corrosion, the use of corrosion inhibitor chemicals in the coolant is essential.

If coolant containing a corrosion inhibitor is not used, the cooling system will accumulate rust and scale in the water jacket and radiator. This will block the coolant passages, and considerably reduce the efficiency of the cooling system.

Coolant Level Inspection

The coolant expansion tank can be viewed from the left hand side of the motorcycle, below and towards the front of the fuel tank.

The coolant level should be checked when the engine is cold (at room or ambient temperature).

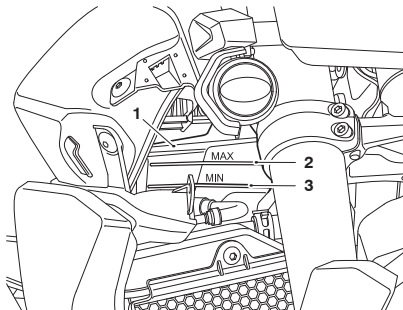

1. Expansion tank
2. MAX mark
3. MIN mark

To inspect the coolant level:

- ▼ Position the motorcycle on level ground and in an upright position (not on the stand).
- ▼ Check the coolant level in the expansion tank.
- ▼ The coolant level must be between the MAX and MIN marks. If the coolant is below the minimum level, the coolant level must be adjusted.

Coolant Level Adjustment

Warning

Do not remove the expansion tank or radiator pressure cap when the engine is hot.

When the engine is hot, the coolant inside the radiator will be hot and also under pressure.

Contact with this hot, pressurized coolant will cause scalds and skin damage.

Caution

If hard water is used in the cooling system, it will cause scale accumulation in the engine and radiator and considerably reduce the efficiency of the cooling system.

Reduced cooling system efficiency may cause the engine to overheat and suffer severe damage.

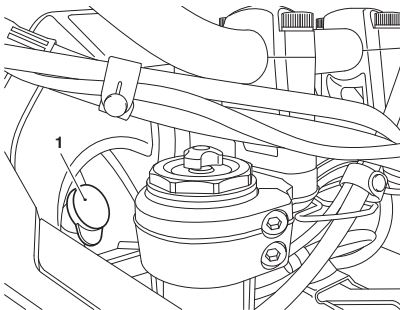

1. Expansion tank cap

To adjust the coolant level:

- ▼ Allow the engine to cool.
- ▼ The expansion tank cap can be removed from the right hand side of the motorcycle, between the front of the fuel tank and the frame.
- ▼ Remove the cap from the expansion tank and add coolant mixture through the filler opening until the level reaches the MAX mark.
- ▼ Reinstall the cap.

Note

If the coolant level is being checked because the coolant has overheated, also check the level in the radiator and top off if necessary.

In an emergency, distilled water can be added to the cooling system. However, the coolant must then be drained and replenished with HD4X Hybrid OAT coolant as soon as possible.

MAINTENANCE

Coolant Change

It is recommended that the coolant is changed by an authorized Triumph dealer in accordance with scheduled maintenance requirements.

Radiator and Hoses

Warning

The fan operates automatically when the engine is running.

Always keep hands and clothing away from the fan.

Contact with the rotating fan may cause an accident and/or personal injury.

Caution

Using high pressure water sprays, such as from a car wash facility or household pressure washer, can damage the radiator fins, cause leaks and impair the radiator's efficiency.

Do not obstruct or deflect airflow through the radiator by installing unauthorized accessories, either in front of the radiator or behind the cooling fan.

Interference with the radiator airflow can cause overheating, potentially resulting in engine damage.

Check the radiator hoses for cracks or deterioration, and tension clips for tightness in accordance with scheduled maintenance requirements. Have your authorized Triumph dealer replace any defective items.

Check the radiator grille and fins for obstructions by insects, leaves or mud. Clean off any obstructions with a stream of low pressure water.

Throttle Control

Warning

Always be alert for changes in the 'feel' of the throttle control and have the throttle system checked by an authorized Triumph dealer if any changes are detected.

Changes can be due to wear in the mechanism, which could lead to a sticking throttle control.

A sticking or stuck throttle control will lead to loss of motorcycle control and an accident.

Clutch

The motorcycle is equipped with a cable-operated clutch.

If the clutch lever has excessive free play, the clutch may not disengage fully. This will cause difficulty in shifting gear and selecting neutral. This may cause the engine to stall and make the motorcycle difficult to control.

Conversely, if the clutch lever has insufficient free play the clutch may not engage fully, causing the clutch to slip, which will reduce performance and cause premature clutch wear.

Clutch lever free play must be checked in accordance with scheduled maintenance requirements.

Clutch Inspection

Check that there is 0.08 - 0.12 in (2 - 3 mm) clutch lever free play at the lever.

If there is an incorrect amount of free play, adjustments must be made.

Clutch Adjustment

To adjust the clutch:

- ▼ Turn the adjuster sleeve until the correct amount of clutch lever free play is achieved.
- ▼ Check that there is 0.08 - 0.12 in (2 - 3 mm) clutch lever free play at the lever.
- ▼ If there is an incorrect amount of free play, adjustments must be made.

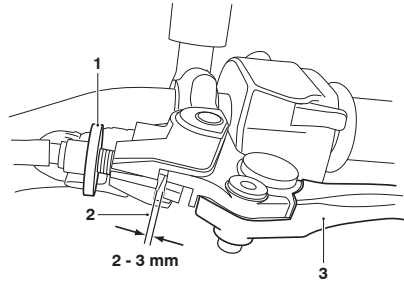

1. Adjuster sleeve (lock nut fully loosened)
2. Correct clearance 0.08 - 0.12 in (2 - 3 mm)
3. Clutch lever

- ▼ If correct adjustment cannot be made using the lever adjuster, use the cable adjuster at the lower end of the cable.
- ▼ Loosen the adjuster lock nut.
- ▼ Turn the outer cable adjuster to give 0.08 - 0.12 in (2 - 3 mm) of free play at the clutch lever.
- ▼ Tighten the locknut to 31 lbf in (3.5 Nm).

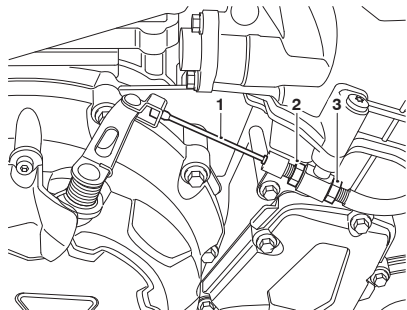

1. Clutch cable
2. Lock nut
3. Adjuster nut

Drive Chain



Warning

A loose or worn chain, or a chain that breaks or jumps off the sprockets could catch on the engine sprocket or lock the rear wheel.

A chain that snags on the engine sprocket will injure the rider and lead to loss of motorcycle control and an accident.

Similarly, locking the rear wheel will lead to loss of motorcycle control and an accident.

For safety and to prevent excessive wear the drive chain must be checked, adjusted and lubricated in accordance with the scheduled maintenance requirements. Checking, adjustment and lubrication must be carried out more frequently for extreme conditions such as high speed riding, salty or heavily gritted roads.

If the chain is badly worn or incorrectly adjusted (either too loose or too tight) the chain could jump off the sprockets or break. Therefore, always replace worn or damaged chains using genuine Triumph parts supplied by an authorized Triumph dealer.

Drive Chain Lubrication

Lubrication is necessary every 200 miles (300 km) and also after riding in wet weather, on wet roads, or any time that the chain appears dry.

To lubricate the drive chain:

- ▼ Use the special drive chain lubricant as recommended in the Specifications section.
- ▼ Apply lubricant to the sides of the rollers then allow the motorcycle to stand unused for at least eight hours (overnight is ideal). This will allow the lubricant to penetrate to the drive chain O-rings etc.
- ▼ Before riding, wipe off any excess lubricant.
- ▼ If the drive chain is especially dirty, clean first and then apply lubricant as mentioned above.

Caution

Do not use a pressure washer to clean the drive chain as this may cause damage to the drive chain components.

Drive Chain Free Movement Inspection

Warning

Make sure the motorcycle is stabilized and adequately supported.

A correctly supported motorcycle will help prevent it from falling.

An unstable motorcycle may fall, causing injury to the operator or damage to the motorcycle.

To inspect the drive chain free movement:

- ▼ Place the motorcycle on a level surface and hold it in an upright position with no weight on it.
- ▼ Rotate the rear wheel by pushing the motorcycle to find the position where the drive chain is tightest, and measure the vertical movement of the drive chain midway between the sprockets.

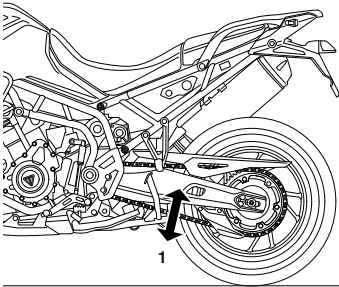

1. Maximum movement position

MAINTENANCE

Drive Chain Free Movement Adjustment

The vertical movement of the drive chain must be in the range shown in the following table.

Model	Vertical Movement Range
Tiger 900 GT (LRH)0.79	0.79 - 1.18 in (20 - 30 mm)
Tiger 850 Sport Tiger 900 GT Tiger 900 GT Pro	0.98 - 1.38 in (25 - 35 mm)
Tiger 900 Rally Tiger 900 Rally Pro1.18 Tiger 900 Bond Edition	1.18 - 1.57 in (30 - 40 mm)

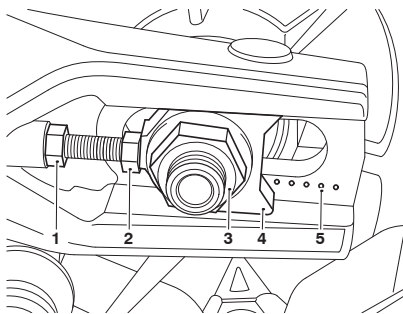

1. Adjuster bolt lock nut
2. Adjuster bolt
3. Rear wheel spindle nut
4. Spindle adjuster
5. Adjuster markers

To adjust the drive chain free movement:

- ▼ Loosen the wheel spindle nut.
- ▼ Loosen the lock nuts on both the left hand and right hand drive chain adjuster bolts.
- ▼ Moving both adjusters by an equal amount, turn the adjuster bolts clockwise to increase drive chain free movement and counterclockwise to reduce drive chain free movement.
- ▼ When the correct amount of drive chain free movement has been set, push the wheel into firm contact with the adjusters.
- ▼ Tighten both adjuster lock nuts to 11 lbf ft (15 Nm) and the rear wheel spindle nut to 81 lbf ft (110 Nm).
- ▼ Repeat the drive chain adjustment check. Readjust if necessary.

Warning

Operation of the motorcycle with insecure adjuster lock nuts or a loose wheel spindle may result in impaired stability and handling of the motorcycle.

This impaired stability and handling may lead to loss of control or an accident.

- ▼ Check the rear brake effectiveness. Rectify if necessary.

Warning

It is dangerous to operate the motorcycle with defective brakes; you must have your authorized Triumph dealer take remedial action before you attempt to ride the motorcycle again.

Failure to take remedial action may reduce braking efficiency leading to loss of motorcycle control or an accident.

Drive Chain and Sprocket Wear Inspection

Warning

Never neglect drive chain maintenance and always have drive chains installed by an authorized Triumph dealer.

Use a genuine Triumph supplied drive chain as specified in the Triumph Parts Catalog.

The use of non-approved drive chains may result in a broken drive chain or may cause the drive chain to jump off the sprockets leading to loss of motorcycle control or an accident.

Caution

If the sprockets are found to be worn, always replace the sprockets and drive chain together.

Replacing worn sprockets without also replacing the drive chain will lead to premature wear of the new sprockets.

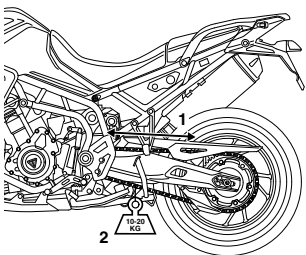

1. Measure across 20 links
2. Weight

To inspect the drive chain and sprocket wear:

- ▼ Remove the drive chain guard.
- ▼ Stretch the drive chain taut by hanging a 20 - 40 lb (10 - 20 kg) weight on the drive chain.
- ▼ Measure the length of 20 links on the straight part of the drive chain from pin center of the 1st pin to the pin center of the 21st pin. Since the drive chain may wear unevenly, take measurements in several places.
- ▼ If the length exceeds the maximum service limit of 12.56 in (319 mm), the drive chain must be replaced.
- ▼ Rotate the rear wheel and inspect the drive chain for damaged rollers, and loose pins and links.
- ▼ Also inspect the sprockets for unevenly or excessively worn or damaged teeth.

Worn Tooth
(Engine Sprocket)

Worn Tooth
(Rear Sprocket)

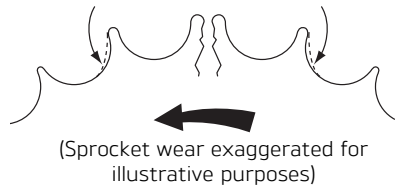

cool

- ▼ If there is any irregularity, have the drive chain and/or the sprockets replaced by an authorized Triumph dealer.
- ▼ Reinstall the drive chain guard, tightening the fasteners to 80 lbf in (9 Nm).

Brakes

Brake Wear Inspection

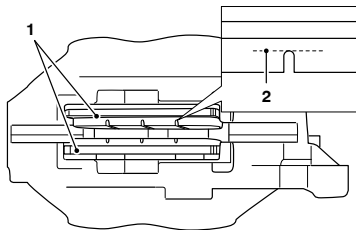

1. Brake pads
2. Minimum thickness line

Brake pads must be inspected in accordance with scheduled requirements and replaced if worn to, or beyond the minimum service thickness.

If the lining thickness of any brake pad (front or rear brakes) is less than 0.06 in (1.5 mm), that is, if the brake pad has worn down to the bottom of the grooves, replace all the brake pads on the wheel.

Breaking-in New Brake Pads and Discs

Warning

Brake pads must always be replaced as a wheel set. At the front, where two calipers are installed on the same wheel, replace all the brake pads in both calipers.

Replacing individual pads will reduce braking efficiency and may cause an accident.

After replacement brake pads have been installed, ride with extreme caution until the new pads have 'broken in'.

New brake discs and pads require a period of careful breaking-in that will optimize the performance and longevity of the discs and pads. The recommended distance for breaking-in new pads and discs is 200 miles (300 km).

During this period, avoid extreme braking, ride with caution and allow for greater braking distances.

Brake Pad Wear Compensation

Warning

If the brake lever or pedal feels soft when it is applied, or if the lever/pedal travel becomes excessive, there may be air in the brake lines and hoses or the brakes may be defective.

It is dangerous to operate the motorcycle under such conditions and your authorized Triumph dealer must rectify the fault before riding.

Riding with defective brakes may lead to loss of motorcycle control and an accident.

Disc and brake pad wear is automatically compensated for and has no effect on the brake lever or pedal action. There are no parts that require adjustment on the front and rear brakes.

Disc Brake Fluid

Warning

Brake fluid is hygroscopic which means it will absorb moisture from the air.

Any absorbed moisture will greatly reduce the boiling point of the brake fluid causing a reduction in braking efficiency.

Because of this, always replace brake fluid in accordance with scheduled maintenance requirements.

Always use new brake fluid from a sealed container and never use fluid from an unsealed container or from one which has been previously opened.

Do not mix different brands or grades of brake fluid.

Check for fluid leakage around brake installed, seals and joints and also check the brake hoses for splits, deterioration and damage.

Always rectify any faults before riding.

Failure to observe and act upon any of these items may cause a dangerous riding condition leading to loss of control and an accident.

Warning

If the ABS is not functioning, the brake system will continue to function as a non-ABS equipped brake system.

In this situation, braking too hard will cause the wheels to lock resulting in loss of control and an accident.

Reduce speed and do not continue to ride for longer than is necessary with the indicator light illuminated. Contact an authorized Triumph dealer as soon as possible to have the fault checked and rectified.

Inspect the level of brake fluid in both reservoirs and change the brake fluid in accordance with scheduled maintenance requirements. Use only DOT 4 fluid as recommended in the Specification section. The brake fluid must also be changed if it becomes, or is suspected of having become contaminated with moisture or any other contaminants.

Note

A special tool is required to bleed the ABS braking system. Contact your authorized Triumph dealer when the brake fluid needs replacing or the hydraulic system requires maintenance.

Front Brake Fluid Level Inspection and Adjustment

Warning

If there has been an appreciable drop in the level of the fluid in either fluid reservoir, consult your authorized Triumph dealer for advice before riding.

Riding with depleted brake fluid levels, or with a brake fluid leak is dangerous and will cause reduced brake performance potentially leading to loss of motorcycle control and an accident.

The front brake fluid reservoir is located on the right hand side handlebar.

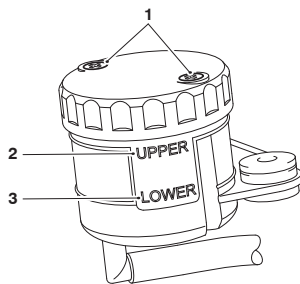

1. Reservoir cap retaining screws
2. UPPER level line
3. LOWER level line

To inspect the front brake fluid level:

- ▼ Check the level of brake fluid visible in the reservoir.
- ▼ The brake fluid level in the reservoir must be kept between the UPPER and LOWER level lines (reservoir held horizontal).

To adjust the front brake fluid level:

- ▼ Loosen the reservoir cap retaining screws and remove the reservoir cap and the diaphragm seal.
- ▼ Fill the reservoir to the UPPER level line using new DOT 4 brake fluid from a sealed container.
- ▼ Install the diaphragm seal into the reservoir cap and make sure that the holes for the fasteners in the reservoir cap and the diaphragm seal are correctly aligned.

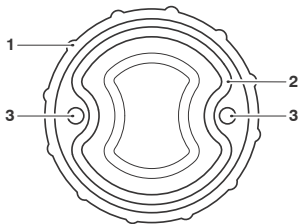

1. Reservoir cap
2. Diaphragm seal
3. Reservoir cap retaining screw holes

- ▼ Install the reservoir cap retaining screws into the reservoir cap and diaphragm seal assembly.

- ▼ Hold the assembly together and position the reservoir cap, diaphragm seal and reservoir cap retaining screws onto the reservoir.

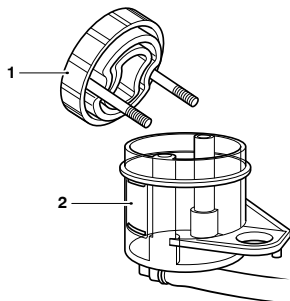

1. Reservoir cap, diaphragm seal and reservoir cap retaining screws assembly
2. Reservoir

Warning

If the reservoir cap retaining screws are over tightened this can result in a brake fluid leak.

A dangerous riding condition leading to loss of motorcycle control and an accident could result if this warning is ignored.

- ▼ Tighten the reservoir cap retaining screws to 6 lbf in (0.7 Nm).

Rear Brake Fluid Level Inspection and Adjustment

Warning

If there has been an appreciable drop in the level of the fluid in either fluid reservoir, consult your authorized Triumph dealer for advice before riding.

Riding with depleted brake fluid levels, or with a brake fluid leak is dangerous and will cause reduced brake performance potentially leading to loss of motorcycle control and an accident.

The reservoir is located on the right hand side for the motorcycle, forward of the exhaust intermediate pipe, below the rider's seat.

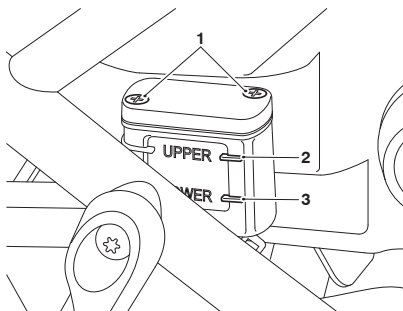

1. Reservoir cap retaining screws
2. UPPER level line
3. LOWER level line

To inspect the rear brake fluid level:

- ▼ Check the level of brake fluid visible in the reservoir.
- ▼ The brake fluid level must be kept between the UPPER and LOWER level lines (reservoir held horizontal).

To adjust the rear brake fluid level:

- ▼ Loosen the reservoir cap retaining screws.
- ▼ Remove the reservoir cap and the diaphragm seal, noting the position of the diaphragm seal for reinstalling.
- ▼ Fill the reservoir to the UPPER level line using new DOT 4 brake fluid from a sealed container.
- ▼ Reinstall the reservoir cap making sure that the diaphragm seal is correctly positioned between the reservoir cap and reservoir body.
- ▼ Replace the reservoir cap retaining screws and tighten to 13.3 lbf in (1.5 Nm).

Brake Light Switches

Warning

Riding the motorcycle with defective brake lights is illegal and dangerous.

An accident causing injury to the rider and other road users may result from use of a motorcycle with defective brake lights.

The brake light is activated independently by either the front or rear brake. If, with the ignition in the ON position, the brake light does not work when the front brake lever is pulled or the rear brake pedal is pressed, have your authorized Triumph dealer investigate and rectify the fault.

Steering Inspection

Warning

Riding the motorcycle with incorrectly adjusted or defective steering head bearings is dangerous and may cause loss of motorcycle control and an accident.

Warning

To prevent risk of injury from the motorcycle falling during the inspection, make sure that the motorcycle is stabilized and secured on a suitable support.

Do not exert extreme force against each wheel or rock each wheel vigorously as this may cause the motorcycle to become unstable and cause injury by falling from its support.

Make sure that the position of the support block will not cause damage to the motorcycle.

Steering Bearings Inspection

The steering head bearings must be lubricated and inspected in accordance with scheduled maintenance requirements. Always inspect the wheel bearings at the same time as the steering bearings.

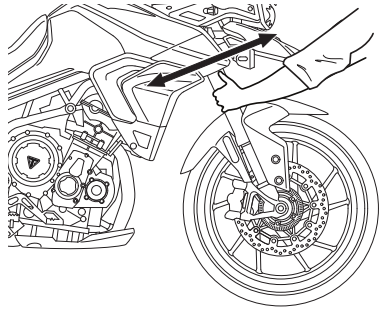

Inspecting the Steering for Free Play

To inspect the steering:

- ▼ Position the motorcycle on level ground, in an upright position.
- ▼ Raise the front wheel above the ground and support the motorcycle.
- ▼ Standing at the front of the motorcycle, hold the lower end of the front forks and try to move them forward and backward.
- ▼ If any free play can be detected in the steering head bearings, ask your authorized Triumph dealer to inspect and rectify any faults before riding.
- ▼ Remove the support and place the motorcycle on the side stand.

Wheel Bearings Inspection

Warning

Riding with worn or damaged front or rear wheel bearings is dangerous and may cause impaired handling and instability leading to an accident.

If in doubt, have the motorcycle inspected by an authorized Triumph dealer before riding.

To inspect the wheel bearings:

- ▼ If the wheel bearings in the front or rear wheel allow play in the wheel hub, are noisy, or if the wheel does not turn smoothly, have your authorized Triumph dealer inspect the wheel bearings.
 - ▼ The wheel bearings must be inspected at the intervals specified in the scheduled maintenance chart.
 - ▼ Position the motorcycle on level ground, in an upright position.
 - ▼ Raise the front wheel above the ground and support the motorcycle.
 - ▼ Standing at the side of the motorcycle, gently rock the top of the front wheel from side to side.
- ▼ If any free play can be detected, ask your authorized Triumph dealer to inspect and rectify any faults before riding.
 - ▼ Reposition the lifting device and repeat the procedure for the rear wheel.
 - ▼ Remove the support and place the motorcycle on the side stand.

Front Suspension

Warning

Riding the motorcycle with defective or damaged suspension is dangerous and may lead to loss of control and an accident.

Warning

Never attempt to dismantle any part of the suspension units
 All suspension units contain pressurized oil.
 Skin and eye damage can result from contact with the pressurized oil.

Front Suspension Adjustment

Tiger 850 Sport Model

This motorcycle has no front suspension adjustment.

All Models except Tiger 850 Sport

The motorcycles are delivered from the factory with the front suspension set at the Solo (normal) riding setting, as detailed in the relevant suspension charts. The front suspension is adjustable and is described in the following sections.

Front Suspension Setting Charts

Warning

Make sure that the correct balance between front and rear suspension is maintained.

Suspension imbalance could significantly change handling characteristics leading to loss of motorcycle control and an accident.

Refer to the tables for further information or consult your authorized Triumph dealer.

The motorcycle is delivered from the factory with the front suspension set at the Solo (normal) riding setting, as shown in the relevant front suspension setting chart. The Solo suspension settings provide a comfortable ride and good handling characteristics for general, solo riding.

The suspension settings charts show suggested settings for the front suspension and are only a guide. Setting requirements may vary for rider weight and personal preferences.

MAINTENANCE

Tiger 900 GT, Tiger 900 GT (LRH) and Tiger 900 GT Pro Front Suspension Settings		
Loading Condition	Compression Damping ¹	Rebound Damping ¹
Solo Riding - Normal	8	10
Solo Riding - Comfort (Softer)	15	15
Solo Riding - Sport (Firmer)	2	2
Solo Riding - Off-Road (Broken Terrain)	18	18
Solo Riding - Off-Road (Smooth Terrain)	8	6
Rider and Luggage	8	10
Rider and Passenger	8	10
Rider, Passenger and Luggage (not exceeding limits)	8	10

¹ Number of clicks counterclockwise from the fully clockwise (closed) position - noting that the first stop (click) is counted as 1.

Tiger 900 Rally, Tiger 900 Rally Pro and Tiger 900 Bond Edition Front Suspension Settings	
Loading Condition	Spring Preload ¹
Solo Riding - Normal	MIN
Solo Riding - Comfort (Softer)	MIN
Solo Riding - Sport (Firmer)	MIN
Solo Riding - Off-Road (All Terrain)	MAX
Rider and Luggage	MIN
Rider and Passenger	MIN
Rider, Passenger and Luggage (not exceeding limits)	MIN

¹ Number of adjuster turns clockwise from the fully counterclockwise position.

Tiger 900 Rally, Tiger 900 Rally Pro and Tiger 900 Bond Edition Front Suspension Settings

Loading Condition	Compression Damping ¹	Rebound Damping ¹
Solo Riding - Normal	8	8
Solo Riding - Comfort (Softer)	15	15
Solo Riding - Sport (Firmer)	3	3
Solo Riding - Off-Road (Broken Terrain)	18	18
Solo Riding - Off-Road (Smooth Terrain)	8	8
Rider and Luggage	8	8
Rider and Passenger	8	6
Rider, Passenger and Luggage (not exceeding limits)	8	6

¹ Number of clicks counterclockwise from the fully clockwise (closed) position - noting that the first stop (click) is counted as 1.

Front Suspension Spring Preload Adjustment

Tiger 900 Rally, Tiger 900 Rally Pro and Tiger 900 Bond Edition

The spring preload adjuster is located at the top of each fork.

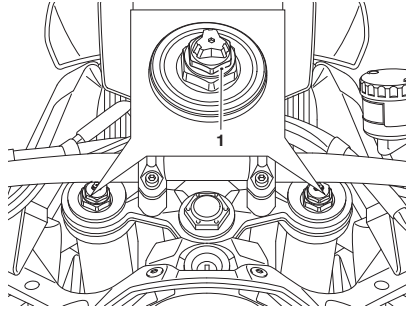

1. Spring preload adjuster

To change the front spring preload setting:

- ▼ Rotate the spring preload adjuster clockwise to increase, or counterclockwise to decrease.
- ▼ Always count the number of turns forward from the fully counterclockwise position.

MAINTENANCE

Front Suspension Compression Damping Adjustment

Tiger 900 Rally, Tiger 900 Rally Pro and Tiger 900 Bond Edition

The compression damping adjuster is located at the top of the right hand fork.

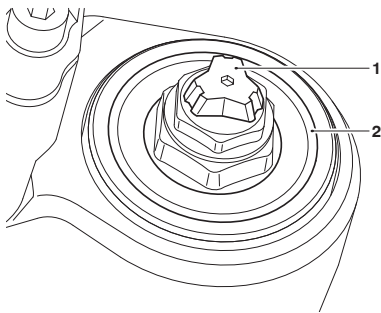

1. Compression damping adjuster
2. Fork top cap

To change the front compression damping setting:

- ▼ Rotate the compression damping adjuster clockwise to increase, or counterclockwise to decrease.
- ▼ Always count the number of clicks back from the fully clockwise (closed) position.

Front Suspension Compression Damping Adjustment

Tiger 900 GT, Tiger 900 GT (LRH) and Tiger 900 GT Pro

The compression damping adjuster is located at the top of the left hand fork.

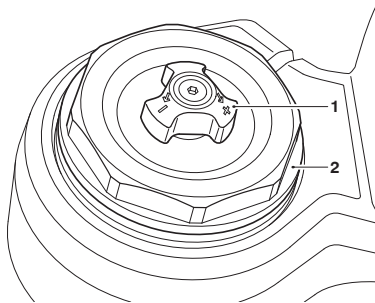

1. Compression damping adjuster
2. Fork top cap

To change the front compression damping setting:

- ▼ Rotate the compression damping adjuster clockwise to increase, or counterclockwise to decrease.
- ▼ Always count the number of clicks back from the fully clockwise (closed) position.

Front Suspension Rebound Damping Adjustment

Tiger 900 Rally, Tiger 900 Rally Pro and Tiger 900 Bond Edition

The rebound damping adjuster is located at the top of the left hand fork.

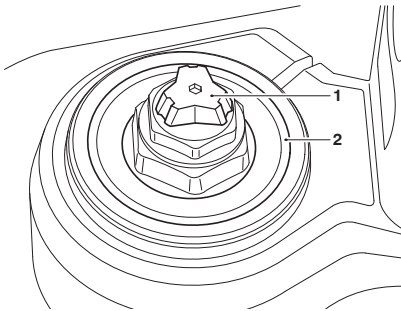

1. Rebound damping adjuster
2. Fork top cap

To change the front rebound damping setting:

- ▼ Rotate the rebound damping adjuster clockwise to increase, or counterclockwise to decrease.
- ▼ Always count the number of clicks back from the fully clockwise (closed) position.

Front Suspension Rebound Damping Adjustment

Tiger 900 GT, Tiger 900 GT (LRH) and Tiger 900 GT Pro

The rebound damping adjuster is located at the top of the right hand fork.

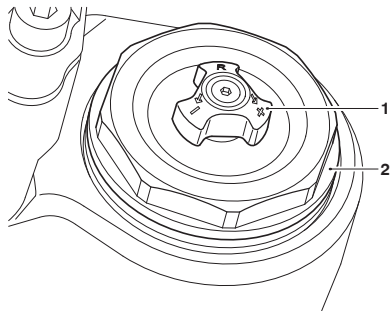

1. Rebound damping adjuster
2. Fork top cap

To change the front rebound damping setting:

- ▼ Rotate the rebound damping adjuster clockwise to increase, or counterclockwise to decrease.
- ▼ Always count the number of clicks back from the fully clockwise (closed) position.

MAINTENANCE

Front Fork Inspection

Warning

Riding the motorcycle with defective or damaged suspension is dangerous and may lead to loss of control and an accident.

Warning

Never attempt to dismantle any part of the suspension units

All suspension units contain pressurized oil.

Skin and eye damage can result from contact with the pressurized oil.

To check that the forks operate smoothly:

- ▼ Position the motorcycle on level ground.
- ▼ While holding the handlebars and applying the front brake, pump the forks up and down several times.
- ▼ If roughness or excessive stiffness is detected, consult your authorized Triumph dealer.
- ▼ If any damage or leakage is found, consult your authorized Triumph dealer.
- ▼ Examine each fork for any sign of damage, scratching of the slider surface, or for oil leaks.

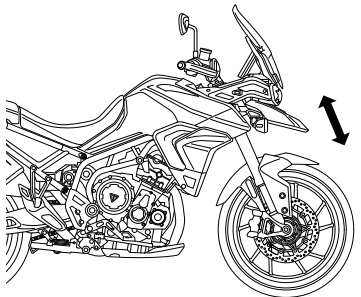

Tiger 900 GT Pro Shown

Rear Suspension

Warning

Riding the motorcycle with defective or damaged suspension is dangerous and may lead to loss of control and an accident.

Warning

Never attempt to dismantle any part of the suspension units
 All suspension units contain pressurized oil.
 Skin and eye damage can result from contact with the pressurized oil.

Rear Suspension Setting Charts

Warning

Make sure that the correct balance between front and rear suspension is maintained.

Suspension imbalance could significantly change handling characteristics leading to loss of motorcycle control and an accident.

Refer to the tables for further information or consult your authorized Triumph dealer.

The motorcycle is delivered from the factory with the rear suspension set at the Solo (normal) riding settings, as shown in the relevant suspension chart. The Solo Riding suspension settings provide a comfortable ride and good handling characteristics for general, solo riding.

The suspension settings charts show suggested settings for the rear suspension and are only a guide. Setting requirements may vary for rider weight and personal preferences.

An increase in spring preload requires firmer damping. A reduction in spring preload requires softer damping. The damping must be adjusted to the road conditions and the spring preload.

MAINTENANCE

Tiger 900 GT Pro Rear Suspension Settings

The Tiger 900 GT Pro has electronically adjustable preload and rebound damping suspension. This is adjusted in the Damping and Suspension menus in the instrument display. For more information, see page 79.

Tiger 850 Sport Rear Suspension Settings	
Loading Condition	Spring Preload ¹
Solo Riding - Normal	MIN
Solo Riding - Comfort (Softer)	MIN
Solo Riding - Sport (Firmer)	MIN
Rider and Luggage	17
Rider and Passenger	21
Rider, Passenger and Luggage (not exceeding limits)	MAX
¹ Number of adjuster turns clockwise from the fully counterclockwise position.	

Tiger 900 GT Rear Suspension Settings		
Loading Condition	Spring Preload ¹	Rebound Damping ²
Solo Riding - Normal	MIN	1.5
Solo Riding - Comfort (Softer)	MIN	2.5
Solo Riding - Sport (Firmer)	MIN	1
Solo Riding - Off-Road (Broken Terrain)	MIN	1.25
Solo Riding - Off-Road (Smooth Terrain)	MIN	0.5
Rider and Luggage	17	1
Rider and Passenger	21	1
Rider, Passenger and Luggage (not exceeding limits)	MAX	0.5
¹ Number of adjuster turns clockwise from the fully counterclockwise position.		
² Number of adjuster turns counterclockwise from the fully clockwise (closed) position.		

Tiger 900 GT (LRH) Rear Suspension Settings		
Loading Condition	Spring Preload ¹	Rebound Damping ²
Solo Riding - Normal	MIN	1.5
Solo Riding - Comfort (Softer)	MIN	2.5
Solo Riding - Sport (Firmer)	MIN	1
Solo Riding - Off-Road (Broken Terrain)	MIN	1.25
Solo Riding - Off-Road (Smooth Terrain)	MIN	0.5
Rider and Luggage	17	1
Rider and Passenger	21	1
Rider, Passenger and Luggage (not exceeding limits)	MAX	0.5

¹Number of adjuster turns clockwise from the fully counterclockwise position.

²Number of adjuster turns counterclockwise from the fully clockwise (closed) position.

Tiger 900 Rally, Tiger 900 Rally Pro and Tiger 900 Bond Edition Rear Suspension Settings		
Loading Condition	Spring Preload ¹	Rebound Damping ²
Solo Riding - Normal	10.5	1.25
Solo Riding - Comfort (Softer)	10.5	2
Solo Riding - Sport (Firmer)	10.5	0.75
Solo Riding - Off-Road (Broken Terrain)	MIN	1
Solo Riding - Off-Road (Smooth Terrain)	MIN	0.5
Rider and Luggage	MAX	1
Rider and Passenger	MAX	0.75
Rider, Passenger and Luggage (not exceeding limits)	MAX	0.5

¹Number of adjuster turns clockwise from the fully counterclockwise position.

²Number of adjuster turns counterclockwise from the fully clockwise (closed) position.

Rear Suspension Spring Preload Adjustment

Tiger 850 Sport, Tiger 900 GT and Tiger 900 GT (LRH)

The spring preload adjuster is situated on the right hand side of the motorcycle, at the top of the rear suspension unit.

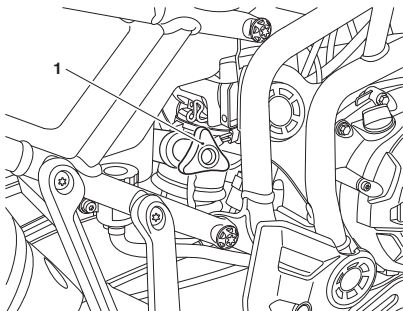

1. Spring preload adjuster

To change the spring preload setting:

- ▼ Rotate the spring preload adjuster clockwise to increase, or counterclockwise to decrease.
- ▼ The setting is measured as the number of adjuster turns clockwise from the fully counterclockwise position.

Rear Suspension Spring Preload Adjustment

Tiger 900 Rally, Tiger 900 Rally Pro and Tiger 900 Bond Edition

The spring preload adjuster is situated on the right hand side of the motorcycle, at the top of the rear suspension unit.

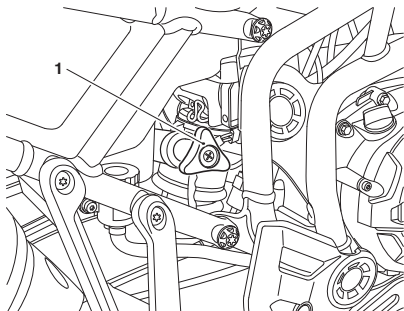

1. Spring preload adjuster

To change the spring preload setting:

- ▼ Rotate the spring preload adjuster clockwise to increase, or counterclockwise to decrease.
- ▼ The setting is measured as the number of adjuster turns clockwise from the fully counterclockwise position.

Rear Suspension Rebound Damping Adjustment

Tiger 900 GT and Tiger 900 GT (LRH)

The rebound damping adjuster is located at the bottom of the rear suspension unit and is accessible from the left hand side of the motorcycle.

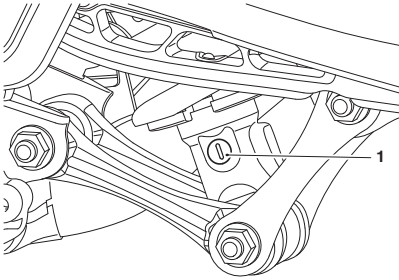

1. Rebound damping adjuster

To change the rebound damping setting:

- ▼ Rotate the slotted adjuster clockwise to increase (harder suspension) and counterclockwise to decrease (softer suspension).
- ▼ The setting is measured as the number of adjuster turns counterclockwise from the fully clockwise position.

Rear Suspension Rebound Damping Adjustment

Tiger 900 Rally, Tiger 900 Rally Pro and Tiger 900 Bond Edition

The rebound damping adjuster is located at the bottom of the rear suspension unit and is accessible from the left hand side of the motorcycle.

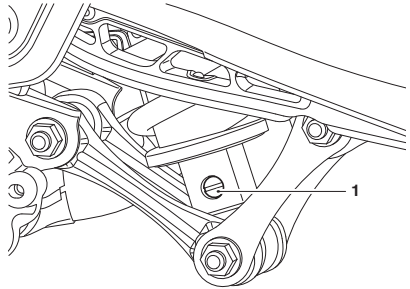

1. Rebound damping adjuster

To change the rebound damping setting:

- ▼ Rotate the slotted adjuster clockwise to increase (harder suspension) and counterclockwise to decrease (softer suspension).
- ▼ The setting is measured as the number of adjuster turns counterclockwise from the fully clockwise position.

Bank Angle Indicators

Warning

Always replace the bank angle indicators before they are worn to their maximum limit.

Use of a motorcycle with bank angle indicators worn beyond the maximum limit will allow the motorcycle to be banked to an unsafe angle.

Banking to an unsafe angle may cause instability, loss of motorcycle control and an accident.

Warning

The bank angle indicators must not be used as a guide to how far the motorcycle may be safely banked.

This depends on many various conditions including, but not limited to, road surface, tire condition and weather.

Banking to an unsafe angle may cause instability, loss of motorcycle control and an accident.

Bank angle indicators are located on the riders footrests.

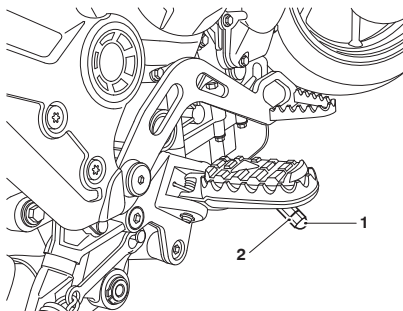

1. Bank angle indicator
2. Maximum wear limit groove

Bank angle indicators must be replaced when they have worn down to the maximum wear limit. The maximum wear limit is shown by a groove on the bank angle indicator.

Regularly check the bank angle indicators for wear.

Tires



cboa

All model variants are equipped with tubeless tires, valves and wheel rims. Use only tires marked TUBELESS and tubeless valves on rims marked SUITABLE FOR TUBELESS TYRES.

Warning

Do not install tube type tires on tubeless rims.

The bead will not seat and the tires could slip on the rims, causing rapid tire deflation that may result in a loss of motorcycle control and an accident.

Never install an inner tube inside a tubeless tire without the appropriate marking. This will cause friction inside the tire and the resulting heat build-up may cause the tube to burst resulting in rapid tire deflation, loss of motorcycle control and an accident.

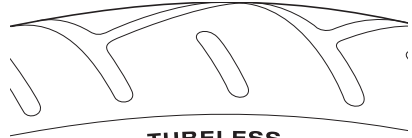

**TUBELESS
RADIAL**

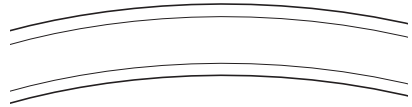

Typical Tire Marking - Tubeless Tire

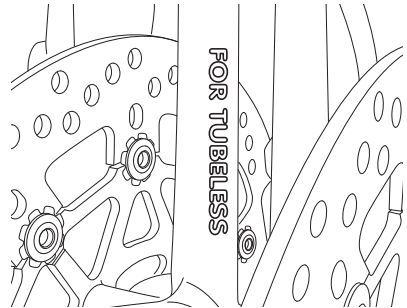

Wheel Marking - Tubeless Wheel

Tire Inflation Pressures

Warning

Incorrect tire inflation will cause abnormal tread wear and instability problems that may lead to loss of control and an accident.

Under inflation may result in the tire slipping on, or coming off the rim. Overinflation will cause instability and accelerated tread wear.

Both conditions are dangerous as they may cause loss of control leading to an accident.

Warning

Tire pressures which have been reduced for off-road riding will impair on-road stability.

Always make sure that the tire pressures are set as described in the Specification section for on-road use.

Operation of the motorcycle with incorrect tire pressures may cause loss of motorcycle control and an accident.

Correct inflation pressure will provide maximum stability, rider comfort and tire life. Always check tire pressures before riding when the tires are cold. Check tire pressures daily and adjust if necessary. See the Specification section for details of the correct inflation pressures.

Tire Pressure Monitoring System (TPMS) (if equipped)

Caution

An adhesive label is installed to the wheel rim to indicate the position of the tire pressure sensor.

Care must be taken when replacing the tires to prevent any damage to the tire pressure sensors.

Always have the tires mounted by an authorized Triumph dealer. It is important to inform them that tire pressure sensors are installed on the wheels before they remove the tires.

Caution

Do not use anti puncture fluid or any other item likely to obstruct air flow to the TPMS sensor's orifices. Any blockage to the air pressure orifice of the TPMS sensor during operation will cause the sensor to become blocked, causing irreparable damage to the TPMS sensor assembly.

Damage caused by the use of anti-puncture fluid or incorrect maintenance is not considered a manufacturing defect and will not be covered under warranty.

Always have the tires mounted by an authorized Triumph dealer. It is important to inform them that tire pressure sensors are installed on the wheels before they remove the tires.

The tire pressures shown on your instruments indicate the actual tire pressure at the time of selecting the display. This may differ from the inflation pressure set when the tires are cold because tires become warmer during riding, causing the air in the tire to expand and increase the inflation pressure. The cold inflation pressures specified by Triumph take account of this.

Only adjust tire pressures when the tires are cold using an accurate pressure gage. Do not use the tire pressure display on the instruments.

Tire Wear

As the tire tread wears down, the tire becomes more susceptible to punctures and failure. It is estimated that 90% of all tire problems occur during the last 10% of tread life (90% worn). It is recommended that tires are changed before they are worn to their minimum tread depth.

Minimum Recommended Tread Depth

Warning

Riding with excessively worn tires is hazardous and will adversely affect traction, stability and handling which may lead to loss of control and an accident.

When tubeless tires, used without a tube, become punctured, leakage is often very slow. Always inspect tires very closely for punctures. Check the tires for cuts, embedded nails or other sharp objects. Riding with punctured or damaged tires will adversely affect motorcycle stability and handling which may lead to loss of control or an accident.

Check the rims for dents or deformation. Riding with damaged or defective wheels or tires is dangerous and may lead to loss of control and an accident.

Always consult your authorized Triumph dealer for tire replacement, or for a safety inspection of the tires.

In accordance with the periodic maintenance chart, measure the depth of the tread with a depth gage, and replace any tire that has worn to, or beyond the minimum allowable tread depth specified in the table below:

Under 80 mph (130 km/h)	0.08 in (2 mm)
Over 80 mph (130 km/h)	Front 0.08 in (2 mm) Rear 0.12 in (3 mm)

Mud and Snow/Dual Purpose Tires (if equipped)

The use of mud and snow/dual purpose tires may result in reduced motorcycle stability. If the stability or handling characteristics of the motorcycle (equipped with the mud and snow/dual purpose tires) begins to change adversely, then check the tire tread depth. It is recommended that mud and snow/dual purpose tires are replaced earlier than normal tires and before they are worn near to the minimum allowable tread depth, see <https://www.triumphmotorcycles.co.uk/owners/your-triumph#tyres>.

Tire Replacement

All Triumph motorcycles are carefully and extensively tested in a range of riding conditions to ensure that the most effective tire combinations are approved for use on each model. It is essential that approved tires mounted in approved combinations, are used when purchasing replacement items. The use of non-approved tires or approved tires in non-approved combinations, may lead to motorcycle instability, loss of control and an accident.

A list of approved tires specific to your motorcycle are available from your authorized Triumph dealer, or on the Internet at www.triumph.co.uk. Always have tires mounted and balanced by your authorized Triumph dealer who has the necessary training and skills to ensure safe, effective mounting.

When replacement tires are required, consult your authorized Triumph dealer who will arrange for the tires to be selected, in a correct combination, from the approved list and mounted according to the tire manufacturer's instructions.

Initially, the new tires will not produce the same handling characteristics as the worn tires and the rider must allow adequate riding distance (approximately 100 miles (160 km)) to become accustomed to the new handling characteristics.

The tire pressures must be checked and adjusted, and the tires examined for correct seating 24 hours after fitting. Rectification must be carried out as necessary. The same checks and adjustments must also be carried out when 100 miles (160 km) have been traveled after mounting.

Warning

Do not install tube type tires on tubeless rims.

The bead will not seat and the tires could slip on the rims, causing rapid tire deflation that may result in a loss of motorcycle control and an accident.

Never install an inner tube inside a tubeless tire without the appropriate marking. This will cause friction inside the tire and the resulting heat build-up may cause the tube to burst resulting in rapid tire deflation, loss of motorcycle control and an accident.

! Warning

If a tire sustains a puncture, the tire must be replaced.

Failure to replace a punctured tire or operation with a repaired tire can lead to instability, loss of motorcycle control or an accident.

! Warning

If tire damage is suspected, such as after striking the curb, ask your authorized Triumph dealer to inspect the tire both internally and externally.

Tire damage may not always be visible from the outside.

Operation of the motorcycle with damaged tires could lead to loss of control and an accident.

! Warning

Use of a motorcycle with incorrectly seated tires, incorrectly adjusted tire pressures, or when not accustomed to its handling characteristics may lead to loss of motorcycle control and an accident.

! Warning

ABS operates by comparing the relative speed of the front and rear wheels.

Use of non-recommended tires can affect wheel speed and cause the ABS function not to operate, potentially leading to loss of motorcycle control and an accident in conditions where the ABS would normally function.

! Warning

Accurate wheel balance is necessary for safe, stable handling of the motorcycle. Do not remove or change any wheel balance weights. Incorrect wheel balance may cause instability leading to loss of control and an accident.

When wheel balancing is required, such as after tire replacement, see your authorized Triumph dealer.

Only use self-adhesive weights. Clip on weights may damage the wheel or tire resulting in tire deflation, loss of motorcycle control and an accident.

! Warning

Tires that have been used on a rolling road dynamometer may become damaged. In some cases, the damage may not be visible on the external surface of the tire.

Tires must be replaced after such use as continued use of a damaged tire may lead to instability, loss of motorcycle control and an accident.

Battery

⚠ Warning

The battery contains sulfuric acid (battery acid). Contact with skin or eyes may cause severe burns. Wear protective clothing and a face shield.

If battery acid gets on your skin, flush with water immediately.

If battery acid gets in your eyes, flush with water for at least 15 minutes and SEEK MEDICAL ATTENTION IMMEDIATELY.

If battery acid is swallowed, drink large quantities of water and SEEK MEDICAL ATTENTION IMMEDIATELY.

KEEP BATTERY ACID OUT OF THE REACH OF CHILDREN.

⚠ Warning

Under certain circumstances, the battery may release explosive gases. Make sure to keep all sparks, flames and cigarettes away from the battery.

Do not attach jump leads to the battery, touch the battery cables together or reverse the polarity of the cables, as any of these actions may cause a spark which would ignite battery gases causing a risk of personal injury.

Make sure that there is adequate ventilation when charging or using the battery in an enclosed space.

⚠ Warning

The battery contains harmful materials. Always keep children and pets away from the battery at all times.

Battery Removal

⚠ Warning

Make sure that the battery terminals do not touch the motorcycle frame.

This may cause a short circuit or spark which would ignite battery gases causing a risk of personal injury.

To remove the battery:

- ▼ Remove the passenger seat, see page 97.
- ▼ Remove the rider's seat, see page 98.

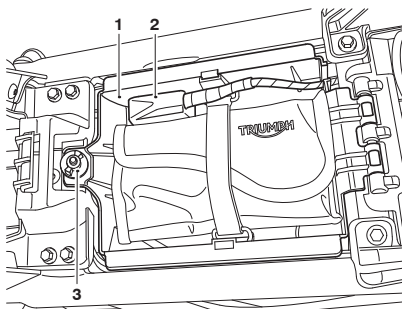

1. Tool kit tray (if equipped)
2. Diagnostic connector
3. Tool kit tray fastener

- ▼ Loosen and remove the tool kit tray fastener (if equipped with the tool kit tray).

- ▼ Lift the tool kit tray up and to the rear of the motorcycle until it stops in an upright position.

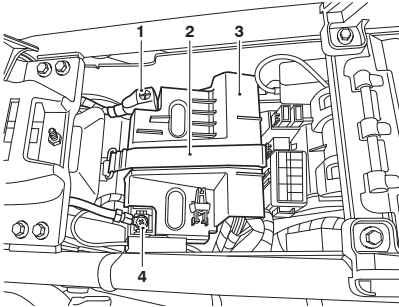

1. Positive (+) terminal
2. Battery strap
3. Battery cover
4. Negative (-) terminal

- ▼ Remove the battery strap.
- ▼ Remove the battery cover, noting the orientation of the cover and the leads.
- ▼ Disconnect the battery leads, negative lead first.
- ▼ Remove the battery out of the case.

Battery Disposal

Should the battery ever require replacement, the original battery must be handed to a recycling agent who will make sure that the dangerous substances from which the battery is manufactured do not pollute the environment.

Battery Maintenance

Warning

Battery acid is corrosive and poisonous and will cause damage to unprotected skin.

Never swallow battery acid or allow it to come into contact with the skin.

To prevent injury, always wear eye and skin protection when handling the battery.

The battery is a sealed type and does not require any maintenance other than checking the voltage and routine recharging when required, such as during storage.

Clean the battery using a clean, dry cloth. Make sure that the cable connections are clean.

It is not possible to adjust the battery acid level in the battery; the sealing strip must not be removed.

Battery Discharge **Caution**

The charge level in the battery must be maintained to maximize battery life.

Failure to maintain the battery charge level could cause serious internal damage to the battery.

Under normal conditions, the motorcycle charging system will keep the battery fully charged. However, if the motorcycle is unused, the battery will gradually discharge due to a normal process called self discharge; the clock, Engine Control Module (ECM) memory, high ambient temperatures, or the addition of electrical security systems or other electrical accessories will all increase this rate of battery discharge. Disconnecting the battery from the motorcycle during storage will reduce the rate of discharge.

Battery Discharge During Storage and Infrequent Use of the Motorcycle

During storage or infrequent use of the motorcycle, inspect the battery voltage weekly using a multimeter. Follow the manufacturer's instructions supplied with the meter.

Should the battery voltage fall below 12.7 Volts, the battery should be charged.

Allowing a battery to discharge or leaving it discharged for even a short period of time causes sulphation of the lead plates. Sulphation is a normal part of the chemical reaction inside the battery, however over time the sulphate can crystallize on the plates making recovery difficult or impossible. This permanent damage is not covered by the motorcycle warranty, as it is not due to a manufacturing defect.

Keeping the battery fully charged reduces the likelihood of it freezing in cold conditions. Allowing a battery to freeze will cause serious internal damage to the battery.

Battery Charging

Warning

The battery contains sulfuric acid (battery acid). Contact with skin or eyes may cause severe burns. Wear protective clothing and a face shield.

If battery acid gets on your skin, flush with water immediately.

If battery acid gets in your eyes, flush with water for at least 15 minutes and **SEEK MEDICAL ATTENTION IMMEDIATELY.**

If battery acid is swallowed, drink large quantities of water and **SEEK MEDICAL ATTENTION IMMEDIATELY.**

KEEP BATTERY ACID OUT OF THE REACH OF CHILDREN.

Caution

Do not use an automotive quick charger as it may overcharge and damage the battery.

For help with selecting a battery charger, checking the battery voltage or battery charging, contact your local authorized Triumph dealer.

Should the battery voltage fall below 12.7 Volts, the battery should be charged using a Triumph approved battery charger. Always remove the battery from the motorcycle and follow the instructions supplied with the battery charger.

For extended periods of storage (beyond two weeks) the battery should be removed from the motorcycle and kept charged using a Triumph approved maintenance charger.

Similarly, should the battery charge fall to a level where it will not start the motorcycle, remove the battery from the motorcycle before charging.

Battery Installation

Warning

Make sure that the battery terminals do not touch the motorcycle frame.

This may cause a short circuit or spark which would ignite battery gases causing a risk of personal injury.

To install the battery:

- ▼ Place the battery in the battery case.
- ▼ Reconnect the battery, positive lead (red protective cover) first and tighten the battery terminals to 39.8 lbf in (4.5 Nm).

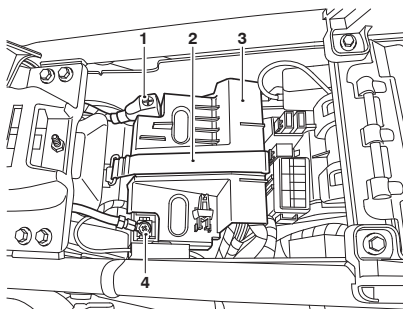

1. Positive (+) terminal
2. Battery strap
3. Battery cover
4. Negative (-) terminal

- ▼ Apply a light coat of grease to the terminals to prevent corrosion.
- ▼ Cover the positive terminal with the red protective cap.
- ▼ Reinstall the battery cover.

- ▼ Reinstall the battery strap.

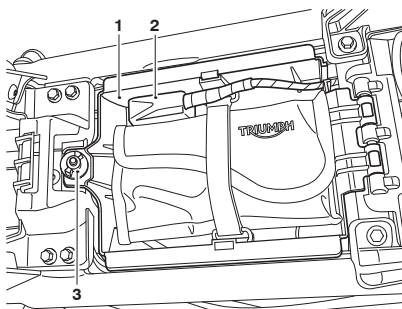

1. Tool kit tray (if equipped)
2. Diagnostic connector
3. Tool kit tray fastener

- ▼ Lower the tool kit tray (if equipped) into its original location. Reinstall and tighten the tool kit tray fastener.
- ▼ Place the diagnostic connector and any other loose items securely in the tool kit tray.
- ▼ Reinstall the rider's seat, see page 98.
- ▼ Re-install the passenger seat, see page 97.

Fuses

Warning

Always replace blown fuses with new ones of the correct rating (as specified on the fuse box cover).

Never replace a blown fuse with a fuse of a different rating.

Use of an incorrect fuse could lead to an electrical problem, resulting in motorcycle damage, loss of motorcycle control and an accident.

A blown fuse is indicated when all of the systems protected by that fuse become inoperative. When checking for a blown fuse, use the relevant tables to establish which fuse has blown.

If the motorcycle is equipped with rider mode settings, then before disconnecting the battery or removing a fuse, note and record the rider mode settings. Once the fuse has been reinstalled or the battery reconnected then the rider mode settings should be reset as noted.

Fuse Box Locations

The fuse boxes are located beneath the rider's seat. To allow access to the fuse boxes, the passenger seat and then the rider's seat must be removed (see page 97 and page 98).

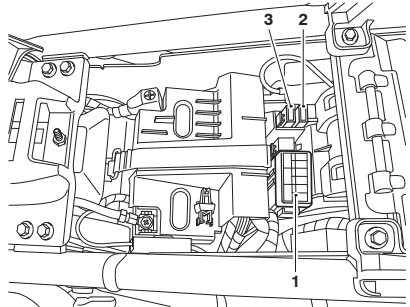

1. Fuse box 1 - all models
2. Fuse box 2 - all models
3. Fuse box 3 - Tiger 900 GT Pro only

Note

The starter solenoid has an additional 30 Amp fuse, attached directly to the solenoid under the battery, beneath the rider's seat.

Fuse Identification

Tiger 850 Sport

The fuse identification numbers listed in the tables correspond with those printed on the fuse box covers, as shown below.

Fuse Box 1

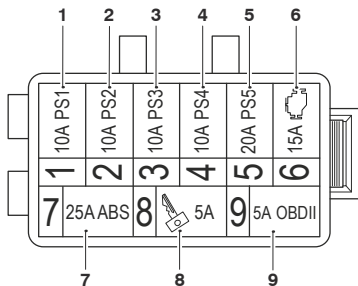

Position	Circuit Protected	Rating (Amps)
1	Chassis Control Unit, Cooling Fan (Right Hand Side), Horn, License Plate Light, Rear Position Light	10
2	Chassis Control Unit, Brake Light, Dip Beam Headlight, Instrument Wake, Front Turn Signals, Heated Grips	10
3	Chassis Control Unit, High Beam Headlight, Rear Turn Signals, USB Charger, Front Position Light Power	10
4	Chassis Control Unit, Passenger Accessory Socket	10
5	Chassis Control Unit, Cooling Fan (Left Hand Side), Starter Motor Solenoid, Fuel Pump	20
6	Engine Management System	15
7	ABS	25
8	Ignition Switch	5
9	Diagnostics Connector (OBDII), Alarm	5

Fuse Box 2

Position	Circuit Protected	Rating (Amps)
1	Rider Accessory Socket	10

Fuse Identification

**Tiger 900 GT, Tiger 900 GT (LRH),
Tiger 900 Rally, Tiger 900 Rally Pro and
Tiger 900 Bond Edition**

The fuse identification numbers listed in the tables correspond with those printed on the fuse box covers, as shown below.

Fuse Box 1

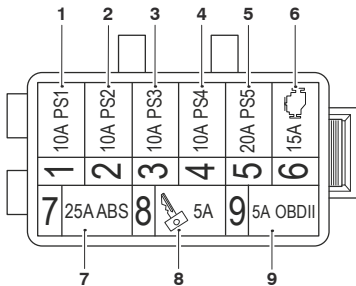

Position	Circuit Protected	Rating (Amps)
1	Chassis Control Unit, Cooling Fan (Right Hand Side), Horn, Fog Lights, License Plate Light, Rear Position Light	10
2	Chassis Control Unit, Brake Light, Dip Beam Headlight, Front Position/DRL Control, Instrument Wake, Front Turn Signals, Heated Grips	10
3	Chassis Control Unit, Heated Seats, High Beam Headlight, Rear Turn Signals, USB Charger, Front Position/DRL Power	10
4	Chassis Control Unit, Passenger Accessory Socket	10
5	Chassis Control Unit, Cooling Fan (Left Hand Side), Starter Motor Solenoid, Fuel Pump	20
6	Engine Management System	15
7	ABS	25
8	Ignition Switch	5
9	Diagnostics Connector (OBDII), Alarm	5

Fuse Box 2

Position	Circuit Protected	Rating (Amps)
1	Rider Accessory Socket	10

Fuse Identification

Tiger 900 GT Pro

The fuse identification numbers listed in the table correspond with those printed on the fuse box covers, as shown below.

Fuse Box 1

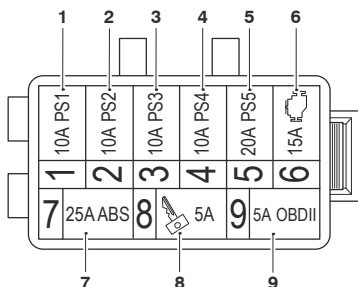

Position	Circuit Protected	Rating (Amps)
1	Chassis Control Unit, Cooling Fan (Right Hand Side), Horn, Fog Lights, License Plate Light, Rear Position Light	10
2	Chassis Control Unit, Brake Light, Dip Beam Headlight, Front Position/DRL Control, Instrument Wake, Front Turn Signals, Heated Grips	10
3	Chassis Control Unit, Heated Seats, High Beam Headlight, Rear Turn Signals, USB Charger, Front Position/DRL Power	10
4	Chassis Control Unit, Passenger Accessory Socket	10
5	Chassis Control Unit, Cooling Fan (Left Hand Side), Starter Motor Solenoid, Fuel Pump	20
6	Engine Management System	15
7	ABS	25
8	Ignition Switch	5
9	Diagnostics Connector (OBDII), Alarm	5

Fuse Box 2

Position	Circuit Protected	Rating (Amps)
1	Rider Accessory Socket	10

Fuse Box 3

Position	Circuit Protected	Rating (Amps)
1	Suspension Control	15

Headlights



Warning

Adjust road speed to suit the visibility and weather conditions in which the motorcycle is being operated.

Make sure that the headlight beam is adjusted to illuminate the road surface sufficiently far ahead without blinding oncoming traffic.

An incorrectly adjusted headlight may impair visibility causing an accident.

Warning

Never attempt to adjust a headlight beam when the motorcycle is in motion.

Any attempt to adjust a headlight beam when the motorcycle is in motion may result in loss of control and an accident.

Caution

Do not cover the headlight or lens with any item likely to obstruct air flow to, or prevent heat escaping from, the headlight lens.

Covering the headlight lens during operation with items of clothing, luggage, adhesive tape, devices intended to alter or adjust the headlight beam or non genuine headlight lens covers will cause the headlight lens to overheat and distort, causing irreparable damage to the headlight assembly.

Damage caused by overheating is not considered a manufacturing defect and will not be covered under warranty.

If the headlight must be covered during use - such as taping of the headlight lens required during closed-course conditions - the headlight must be disconnected.

Caution

The use of non-approved headlight units may result in damage to the headlight unit and/or motorcycle.

Use a genuine Triumph supplied headlight unit as specified in the Triumph Parts Catalog.

Always have replacement headlight units installed by an authorized Triumph dealer.

Headlights Adjustment

The headlights can be adjusted by means of a vertical adjustment screw located on the rear of the headlight unit. There is no horizontal adjustment.

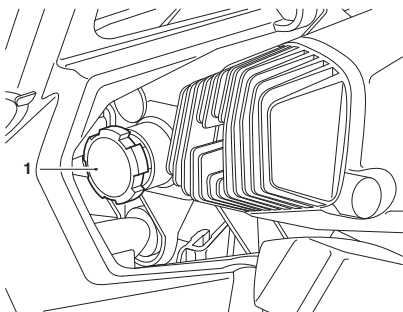
**1. Vertical adjustment screw**

To adjust the headlight:

- ▼ Switch the headlight dipped beam on.
- ▼ Turn the vertical adjustment screw on the headlight unit clockwise to lower the beam or counterclockwise to raise the beam.
- ▼ Switch the headlights off when the beam settings are satisfactory.

Note

There is a small triangle marking on each side of the headlight unit which indicates the height of the light within the headlight unit for adjustment purposes.

Headlights Replacement

The headlight unit is a sealed, maintenance free LED unit. The headlight unit must be replaced in the event of a failure.

Daytime Running Light (DRL) (if equipped)

The Daytime Running Light (DRL) is situated within the headlight assembly and is a sealed, maintenance free LED unit. The headlight unit must be replaced in the event of the failure of the DRL.

Lights

 **Caution**

The use of non-approved bulbs may result in damage to lenses and other lighting unit components.

In addition, the use of bulbs of incorrect wattage may cause the chassis ECM to cut power to affected lighting circuits.

Use genuine Triumph supplied bulbs as specified in the Triumph Parts Catalog.

Always have replacement bulbs installed by an authorized Triumph dealer.

Turn Signal Lights

The motorcycle is equipped with either LED or bulb turn signal lights.

LED Turn Signal Lights

The turn signal light units are sealed, maintenance free LED units.

Bulb Turn Signal Lights

To replace the turn signal bulb:

- ▼ The lens on each turn signal light is held in place by a securing screw located either in the lens of the light or the light housing.
- ▼ Loosen the screw and remove the lens.
- ▼ Carefully remove the turn signal bulb.
- ▼ Installation is the reverse of the removal procedure.

Tail/Brake Light / License Plate Light

The tail light unit is a sealed, maintenance free LED unit. The license plate light is integral to the brake/tail light unit.

Fog Lights (if equipped)

The fog light units are sealed, maintenance free LED units.

Mirrors **Warning**

Never attempt to clean or adjust mirrors while riding the motorcycle. Removal of the rider's hands from the handlebars while riding the motorcycle will diminish the ability of the rider to maintain control of the motorcycle.

Attempting to clean or adjust mirrors while riding the motorcycle may result in loss of control of the motorcycle and an accident.

Only attempt to clean or adjust the mirrors while stationary.

 **Warning**

Operation of the motorcycle with incorrectly adjusted mirrors is dangerous.

Operation of the motorcycle with incorrectly adjusted mirrors will result in loss of vision to the rear of the motorcycle. It is dangerous to ride a motorcycle without sufficient rearward vision.

Always adjust the mirrors to provide sufficient rearward vision before riding the motorcycle.

Table of Contents

Cleaning	188
Preparation for Washing.....	188
Where to be Careful.....	189
Washing.....	189
After Washing.....	190
Gloss Paintwork Care.....	190
Matt Paintwork Care	190
Aluminum Items - not Lacquered or Painted	191
Chrome and Stainless Steel Care	191
Black Chrome Care	192
Exhaust System Care.....	192
Seat Care.....	193
Windshield Care (if equipped).....	194
Leather Products Care.....	195
Preparation for Storage	196
Preparation after Storage.....	197

CLEANING AND STORAGE

Cleaning

Frequent, regular cleaning is an essential part of the maintenance of your motorcycle. If regularly cleaned, the appearance will be preserved for many years.

Cleaning with cold water containing an automotive cleaner is essential at all times but particularly so after exposure to sea breezes, sea water, dusty or muddy roads and in winter when roads are treated for ice and snow.

Do not use household detergent, as the use of such products will lead to premature corrosion.

Although, under the terms of your motorcycle warranty, cover is provided against the corrosion of certain items, the owner is expected to observe this reasonable advice which will safeguard against corrosion and enhance the appearance of the motorcycle.

Preparation for Washing

Before washing, precautions must be taken to keep water off the following places.

Rear opening of the exhausts: Cover with a plastic bag secured with rubber bands.

Clutch and brake levers, switch housings on the handlebar: Cover with plastic bags.

Ignition switch and steering lock: Cover the keyhole (if applicable) with tape.

Remove any items of jewelry such as rings, watches, zips or belt buckles, which may scratch or otherwise damage painted or polished surfaces.

Use separate cleaning sponges or cleaning cloths for washing painted/polished surfaces and chassis areas. Chassis areas (such as wheels and under fenders) will be exposed to more abrasive road grime and dust, which may then scratch painted or polished surfaces, if the same sponge or cleaning cloths are used.

Where to be Careful

Caution

Do not use high pressure spray washers or steam cleaners.

Use of high pressure spray washers and steam cleaners may damage seals, and cause water and steam to be forced into bearings and other components causing premature wear from corrosion and loss of lubrication.

Caution

Do not spray any water at all near the air intake duct.

The air intake duct is located under the rider's seat, under the fuel tank or near the steering head.

Any water sprayed in this area could enter the airbox and engine, causing damage to both items.

Do not get water near the following places:

- ▼ Air and any intake duct
- ▼ Any visible electrical components
- ▼ Brake cylinders and brake calipers
- ▼ Handlebar switch housings
- ▼ Steering head bearings
- ▼ Instruments
- ▼ Oil filler cap
- ▼ Rear bevel box breather (if equipped)
- ▼ Rear of headlights
- ▼ Seats
- ▼ Suspension seals and bearings
- ▼ Under the fuel tank
- ▼ Wheel bearings.

Washing

To wash the motorcycle, do the following:

- ▼ Make sure that the motorcycle engine is cold.
- ▼ Prepare a mixture of clean, cold water and mild automotive cleaner or low alkaline soap.
- ▼ Do not use a highly alkaline soap as commonly found at commercial car washes because it will leave a residue on painted surfaces and may also cause water spotting.
- ▼ Wash the motorcycle with a sponge or soft cloth.
- ▼ Do not use abrasive scouring pads or steel wool. They will damage the finish.
- ▼ Rinse the motorcycle thoroughly with clean, cold water.

After Washing

 **Warning**

Never wax or lubricate the brake discs. Always clean the brake disc with a proprietary brand of oil-free brake disc cleaner.

Waxed or lubricated brake discs may cause loss of braking power and an accident.

After washing the motorcycle, do the following:

- ▼ Remove the plastic bags and tape, and clear the air intakes.
- ▼ Lubricate the pivots, bolts and nuts.
- ▼ Test the brakes before motorcycle operation.
- ▼ Use a dry cloth or chamois leather to absorb water residue. Do not allow water to stand on the motorcycle as this will lead to corrosion.
- ▼ Start the engine and run it for 5 minutes. Make sure that there is adequate ventilation for the exhaust fumes.

Gloss Paintwork Care

Gloss paintwork should be washed and dried as described previously, then protected using a high quality automotive polish. Always follow the manufacturer's instructions and repeat regularly to maintain your motorcycle's appearance.

Matt Paintwork Care

Matt paintwork requires no greater care than that already recommended for gloss paintwork.

- ▼ Do not use any polish or wax on matt paintwork.
- ▼ Do not try and polish out scratches.

Aluminum Items - not Lacquered or Painted

Items such as brake and clutch levers, wheels, engine covers, engine cooling fins, upper and lower yokes and throttle bodies on some models must be correctly cleaned to preserve their appearance. Please contact your dealer if you are unsure which components on your motorcycle are aluminum parts not protected by paint or lacquer, and for guidance on how to clean those items.

Use a proprietary brand of aluminum cleaner which does not contain abrasive or caustic elements.

Clean aluminum items regularly, in particular after use in inclement weather, where the components must be hand washed and dried each time the machine is used.

Warranty claims due to inadequate maintenance will not be allowed.

Chrome and Stainless Steel Care

All chrome and stainless steel parts of your motorcycle must be cleaned regularly to avoid a deterioration of its appearance.

Washing

Wash as previously described.

Drying

Dry the chrome and stainless steel parts as far as possible with a soft cloth or chamois leather.

Protecting



Caution

The use of products containing silicone will cause discoloration of the chrome and stainless steel parts and must not be used.

The use of abrasive cleaning products will damage the finish and must not be used.

When the chrome and stainless steel is dry, apply a suitable proprietary chrome cleaner on to the surface, following the manufacturer's instructions.

It is recommended that regular protection be applied to the motorcycle as this will both protect and enhance its appearance.

CLEANING AND STORAGE

Black Chrome Care

Items such as headlight bowls and mirrors on some models must be correctly cleaned to preserve their appearance. Please contact your dealer if you are unsure which components on your motorcycle are black chrome parts. Maintain the appearance of black chrome items by rubbing a small amount of light oil into the surface.

Exhaust System Care

All parts of the exhaust system of your motorcycle must be cleaned regularly to avoid a deterioration of its appearance. These instructions can be applied to chrome, brushed stainless steel and carbon fiber components; matt painted exhaust systems should be cleaned as above, noting the care instructions in the Matt Paintwork section previously.

Note

The exhaust system must be cool before washing to prevent water spotting.

Washing

Wash as previously described.

Make sure that no soap or water enters the exhausts.

Drying

Dry the exhaust system as far as possible with a soft cloth or chamois leather. Do not run the engine to dry the system or spotting will occur.

Protecting

Caution

The use of products containing silicone will cause discoloration of the chrome and stainless steel parts and must not be used.

The use of abrasive cleaning products will damage the finish and must not be used.

When the exhaust system is dry, apply a suitable proprietary motorcycle protection spray onto the surface, following the manufacturer's instructions.

It is recommended that regular protection be applied to the system as this will both protect and enhance the system's appearance.

Seat Care

Caution

Do not use chemicals or high pressure spray washers to clean the seat.

Using chemicals or high pressure spray washers may damage the seat cover.

To help maintain its appearance, clean the seat using a sponge or cleaning cloth with soap and water.

CLEANING AND STORAGE

Windshield Care (if equipped)



Warning

Never attempt to clean the windshield while the motorcycle is in motion as releasing the handlebars may cause loss of motorcycle control and an accident.

Operation of the motorcycle with a damaged or scratched windshield will reduce the rider's forward vision. Any such reduction in forward vision is dangerous and may lead to loss of motorcycle control and an accident.

Caution

Corrosive chemicals such as battery acid will damage the windshield. Never allow corrosive chemicals to contact the windshield.

Caution

Products such as window cleaning fluids, insect remover, rain repellent, scouring compounds, gasoline or strong solvents such as alcohol, acetone, carbon tetrachloride, etc. will damage the windshield.

Never allow these products to contact the windshield.

Clean the windshield with a solution of mild soap or detergent and clean, cold water.

After cleaning, rinse well and then dry with a soft, lint-free cloth.

If the transparency of the windshield is reduced by scratches or oxidation which cannot be removed, the windshield must be replaced.

Leather Products Care

It is recommend that the leather products are periodically cleaned with a damp cloth and allowed to dry naturally at room temperature. This will maintain the appearance of the leather and ensure the long life of the product.

The Triumph leather product is a natural product and lack of care can result in damage and permanent wear.

Follow these simple instructions to prolong the life of the leather product:

- ▼ Do not use household cleaning products, bleach, detergents containing bleach or any kind of solvent to clean the leather product.
 - ▼ Do not immerse the leather product in water.
 - ▼ Avoid direct heat from fires and radiators which can dry out and distort the leather.
 - ▼ Do not leave the leather product in direct sunlight for prolonged periods of time.
 - ▼ Do not dry the leather product by applying direct heat to it at any time.
 - ▼ If the leather product does get wet, absorb any excess water with a soft clean cloth then leave the leather product to dry naturally at room temperature.
 - ▼ Avoid exposure of the leather product to high levels of salt, for example sea/salt water or road surfaces that have been treated during the winter for ice and snow.
- ▼ If exposure to salt is unavoidable, clean the leather product immediately after each exposure using a damp cloth then leave the leather product to dry naturally at room temperature.
 - ▼ Gently clean any minor marks with a damp cloth then leave the leather product to dry naturally at room temperature.
 - ▼ Place the leather product in a fabric bag or cardboard box to protect it when in storage. Do not use a plastic bag.

CLEANING AND STORAGE

Preparation for Storage

To prepare the motorcycle for storage, do the following:

- ▼ Clean and dry the entire vehicle thoroughly.
- ▼ Fill the fuel tank with the correct grade of unleaded fuel and add a fuel stabilizer (if available), following the fuel stabilizer manufacturer's instructions.

Warning

Gasoline is extremely flammable and can be explosive under certain conditions.

Turn the ignition switch off. Do not smoke.

Make sure the area is well ventilated and free from any source of flame or sparks; this includes any appliance with a pilot light.

- ▼ Remove the spark plug from each cylinder and put several drops (0.17 fl oz / 5 cc) of engine oil into each cylinder. Cover the spark plug holes with a piece of cloth or rag. With the engine stop switch in the RUN position, push the starter button for a few seconds to coat the cylinder walls with oil. Install the spark plugs, tightening to 9 lbf ft (12 Nm).
- ▼ Change the engine oil and filter (see page 138).
- ▼ Check and if necessary correct the tire pressures (see page 211).
- ▼ Set the motorcycle on a stand so that both wheels are raised off the ground. (If this cannot be done, put boards under the front and rear wheels to keep dampness away from the tires.)
- ▼ Spray rust inhibiting oil (there are a host of products on the market and your dealer will be able to offer you local advice) on all unpainted metal surfaces to prevent rusting. Prevent oil from getting on rubber parts, brake discs or in the brake calipers.
- ▼ Lubricate and if necessary adjust the drive chain (see page 146).
- ▼ Make sure the cooling system is filled with a 50% mixture of coolant (noting that HD4X Hybrid OAT coolant, as supplied by Triumph, is pre-mixed and requires no dilution) and distilled water solution (see page 141).
- ▼ Remove the battery, and store it where it will not be exposed to direct sunlight, moisture, or freezing temperatures. During storage it should be given a slow charge (one Ampere or less) about once every two weeks (see page 174).
- ▼ Store the motorcycle in a cool, dry area, away from sunlight, and with a minimum daily temperature variation.
- ▼ Put a suitable porous cover over the motorcycle to keep dust and dirt from collecting on it. Avoid using plastic or similar non-breathable, coated materials that restrict air flow and allow heat and moisture to accumulate.

Preparation after Storage

To prepare the motorcycle to be ridden after storage, do the following:

- ▼ Install the battery (if removed) (see page 178).
- ▼ If the motorcycle has been stored for more than four months, change the engine oil (see page 138).
- ▼ Check all the points listed in the Daily Safety Checks section.
- ▼ Before starting the engine, remove the spark plugs from each cylinder.
- ▼ Put the side stand down.
- ▼ Crank the engine on the starter motor several times until the oil pressure light goes out.
- ▼ Reinstall the spark plugs, tightening to 19 lbf ft (2 Nm), and start the engine.
- ▼ Check and if necessary correct the tire pressures.
- ▼ Clean the entire vehicle thoroughly.
- ▼ Check the brakes for correct operation.
- ▼ Test ride the motorcycle at low speeds.

This page intentionally left blank

Table of Contents

Triumph Warranty Terms and Conditions.....	200
Conditions and Exclusions.....	201
Noise Control System Warranty	202
Tampering With The Noise Control System Prohibited.....	203
Emission Control System Warranty.....	204
California Emissions Control Warranty Statement.....	205
Manufacturers Warranty Coverage.....	205
Owners Warranty Responsibility.....	206
What is Covered by this Emission Warranty.....	208
What Is Not Covered By This Emission Warranty	208
Triumph Overseas	209
Caring for your Motorcycle.....	210

WARRANTY

Triumph Warranty Terms and Conditions

Thank you for choosing a Triumph motorcycle. This motorcycle is the product of Triumph's use of proven engineering, exhaustive testing, and continuous striving for superior reliability, safety, and performance.

This section of the Owner's Handbook includes details of the warranty and other useful information concerning your motorcycle.

Make sure that all your owner information is entered in the Triumph Motorcycle Service Handbook that is provided with the motorcycle.

Maintain maximum protection under warranty by making sure your motorcycle is serviced in accordance with the recommendations of the scheduled maintenance chart in this Owner's Handbook.

If you should sell your motorcycle, make sure this Owner's Handbook together with the other relevant documents are passed to the new owner. Please advise the new owner that they can notify Triumph of the change of ownership by completing the form found on the Triumph web site at www.triumphmotorcycles.com.

All new Triumph motorcycles are covered by a 36 (thirty-six) month unlimited mileage warranty, commencing from the date of first registration or the date of sale if the motorcycle remains unregistered.

Within the warranty period, TRIUMPH MOTORCYCLES AMERICA LIMITED warrant the new Triumph motorcycle detailed in the Motorcycle Service Handbook to be free from any defect in materials used in the manufacture, and/or workmanship at the time of its manufacture.

Any part found to be defective during this period will be repaired or replaced at the discretion of TRIUMPH MOTORCYCLES AMERICA LIMITED by an authorized Triumph dealer.

Any part replaced under the warranty will be covered for the remaining period of the warranty.

Any parts replaced under warranty must be returned to TRIUMPH MOTORCYCLES AMERICA LIMITED and will become the property of TRIUMPH MOTORCYCLES AMERICA LIMITED.

TRIUMPH MOTORCYCLES AMERICA LIMITED may, at its discretion make any repairs or replacement of defective parts falling outside the warranty, but such work shall not be deemed to be any admission of liability.

TRIUMPH MOTORCYCLES AMERICA LIMITED will bear labor charges for work carried out under the warranty.

The warranty may be transferred to subsequent owners for the balance of the remaining warranty period.

Conditions and Exclusions

1. The motorcycle must not have been used for competition, misused¹, inadequately or incorrectly serviced or maintained.
2. The motorcycle must not have been subject to any modification, repair or replacement other than as authorized by TRIUMPH MOTORCYCLES AMERICA LIMITED.
3. The motorcycle battery is warranted for 12 (twelve) months from the original date of purchase of the motorcycle. After this 12 (twelve) month period, the battery is excluded from the terms of this warranty. The battery supplied with the motorcycle must be provided with sufficient charge to replenish that lost by the operation of the starting mechanism and/or the use of electrical equipment while the engine is not running. If the motorcycle is placed in to storage, remove the battery, and store it where it will not be exposed to direct sunlight, moisture, or freezing temperatures. During storage it should be given a slow charge (one Ampere or less) approximately once every two weeks.

The warranty does not cover:

- ▼ The cost of transportation of the motorcycle to or from the authorized Triumph dealer, or expenses incurred while the motorcycle is off the road for warranty repairs.
- ▼ Defects caused by the use of parts and accessories not authorized by TRIUMPH MOTORCYCLES AMERICA LIMITED
- ▼ Defects caused by faulty adjustment, or repairs and alterations performed by a NON-AUTHORIZED Triumph dealer
- ▼ The cost of removal and replacement of parts and accessories, unless supplied as original equipment, or recommended by TRIUMPH MOTORCYCLES AMERICA LIMITED.
- ▼ Normal servicing and normal service items, such as spark plugs, oil and air filters are not covered by this warranty. Similarly items which are expected to wear as part of their normal function such as tires, bulbs, chains, brake pads and clutch plates are also excluded, unless there is a manufacturing defect.
- ▼ Defects to the front fork oil seals as they are subject to wear and tear, including but not limited to damage caused by stone chips to the inner fork tubes.

¹ Misuse includes any use not in accordance with the recommendations made in the 'how to ride the motorcycle' section of the Owner's Handbook and any use contrary to the warnings given in that same handbook. In addition, misuse will include, but not be limited to any use of the motorcycle which does not constitute normal road use.

WARRANTY

- ▼ Seats, luggage, paint, chrome, polished aluminum items, or trim deterioration caused by normal wear and tear, exposure or lack of correct maintenance.
- ▼ Motorcycles used on a commercial basis.
- ▼ Defects which have not been reported to an authorized dealer within ten days of discovery of the defect.
- ▼ Motorcycles which have been inadequately lubricated, or for which the wrong fuel or lubricant has been used.

Should a warranty claim become necessary, TRIUMPH MOTORCYCLES AMERICA LIMITED and its authorized dealers shall not be liable for loss of use, inconvenience, lost time, commercial losses or other incidental or consequential damages.

Any statement, condition, representation, description or warranty otherwise contained in any catalog, advertisement or other publication shall not be construed as enlarging, varying or overriding anything contained herein.

TRIUMPH MOTORCYCLES AMERICA LIMITED reserve the right to make alterations or improvements without notification to any model or motorcycle without obligation to do so to motorcycles already sold.

This warranty does not affect your statutory rights.

Noise Control System Warranty



Warning

This product should be checked for repair or replacement if the motorcycle noise has increased significantly through use, otherwise the owner may become subject to penalties under state and local ordinances.

The following warranty applies to the noise control system and is in addition to the general Triumph warranty and the emission control warranty.

Per 40 C.F.R. § 205.173-1, Triumph Motorcycles America Limited, warrants that this exhaust system, at the time of sale, meets all applicable U.S. E.P.A. federal noise standards. This warranty extends to the first person who buys this exhaust system for purposes other than resale, and to all subsequent buyers. Warranty claims should be directed to an authorized Triumph Motorcycles America dealer.

Triumph Motorcycles America Limited warrants to the first, and each subsequent owner, that the vehicle was designed and built so as to conform, at the time of sale, with the regulations of the U.S. Environmental Protection Agency (as tested following F-76 Drive-By test procedure) and, at the time of manufacture, was free from defects in materials and workmanship which would cause the motorcycle not to meet the U.S. Environmental Protection Agency Standards. This noise control system warranty extends for a period of 1 calendar year or 3,730 miles whichever occurs first from the date on which the motorcycle was delivered to the first retail purchaser or, in the case of a demonstration motorcycle or company motorcycle, the date on which the company placed the motorcycle in service prior to retail sale.

Tampering With The Noise Control System Prohibited

Owners are warned that the law prohibits:

- (a) The removal or rendering inoperative by any person other than for purposes of maintenance, repair or replacement, of any device or element of design incorporated into any new vehicle for the purpose of noise control prior to its sale or delivery to the ultimate purchaser or while it is in use and
- (b) the use of the vehicle after such device or element of design has been removed or rendered inoperative by any person.

Acts which are likely to constitute tampering include the following:

1. Removal or tampering with the mufflers, baffles or header pipes or any other component which conducts exhaust gases.
2. Removal of or puncturing of any part of the air intake system.
3. Failure to carry out maintenance as prescribed in the owner's manual.
4. Replacement of any parts of the exhaust or air intake system with parts other than those specified by Triumph Motorcycles America Limited.

WARRANTY

The following items are not covered by the noise control system warranty:

1. Failures which arise through misuse, alterations or accident damage.
2. Replacing, removing, or modifications of any part of the noise control system (consisting of the exhaust system and air intake system) with parts not certified to be noise legal for street use.
3. Triumph Motorcycles America Limited and its authorized dealers shall not be liable for loss of use, inconvenience, lost time, commercial losses or other incidental or consequential damages.
4. Any motorcycle which has had the odometer recorded mileage changed so that the correct mileage of the motorcycle cannot be accurately determined.

Emission Control System Warranty

The following warranty applies to the emission control system and is in addition to the general Triumph warranty and the noise control system warranty.

Triumph Motorcycles America Limited warrants to the first, and each subsequent owner, that the vehicle was designed and built so as to conform, at the time of sale, with the regulations of the U.S. Environmental Protection Agency and the California Air Resources Board and, at the time of manufacture, was free from defects in materials and workmanship which would cause the motorcycle not to meet the U.S. Environmental Protection Agency or California Air Resources Board Standards. This emission control system warranty extends for a period of 5 calendar years or 18,641 miles whichever occurs first, from the date on which the motorcycle was delivered to the first retail purchaser or, in the case of a demonstration motorcycle or company motorcycle, the date on which the company placed the motorcycle in service prior to retail sale.

The following are not covered by the emission control system warranty:

1. Failures which arise through misuse, alterations, accident damage or failure to carry out maintenance as described in the owner's manual.
2. The replacement of any parts required in the maintenance of the emission control system.
3. Triumph Motorcycles America Limited and its authorized dealers shall not be liable for loss of use, inconvenience, lost time, commercial losses or other incidental or consequential damages.
4. Any motorcycle which has had the odometer recorded mileage changed so that the correct mileage of the motorcycle cannot be accurately determined.

California Emissions Control Warranty Statement

Your warranty rights and obligations

The California Air Resources Board and Triumph Motorcycles America Limited are pleased to explain the emission control system on your motorcycle. In California, new motor vehicles must be designed, built and equipped to meet the State's stringent anti-smog standards. Triumph Motorcycles America Limited must warrant the emission control system on your motorcycle for the periods of time listed below provided there has been no abuse, neglect or improper maintenance of your vehicle.

Your emission control system may include parts such as the fuel injection and the ignition system. Also included may be hoses, connectors and other emission related assemblies.

Where a warrantable condition exists, Triumph Motorcycles America Limited will repair your motorcycle at no cost to you including diagnosis, parts and labor.

Manufacturers Warranty Coverage

For a period of use of five years or 18,641 miles, whichever first occurs: If an emission related part on your motorcycle is defective, the parts will be repaired or replaced by Triumph Motorcycles America Limited. This is your emission control system DEFECTS WARRANTY.

WARRANTY

Owners Warranty Responsibility

As the motorcycle owner, you are responsible for the performance of the required maintenance listed in your owner's manual.

Triumph Motorcycles America Limited recommends that you retain all receipts covering maintenance on your motorcycle, but Triumph Motorcycles America Limited cannot deny warranty solely for the lack of receipts or for your failure to ensure the performance of all scheduled maintenance.

You are responsible for presenting your motorcycle to a Triumph Motorcycles America Limited dealer as soon as a problem exists. The warranty repairs should be completed in a reasonable amount of time, not to exceed 30 days.

As the motorcycle owner, you should also be aware that Triumph Motorcycles America Limited may deny you warranty coverage if your motorcycle or a part has failed due to abuse, neglect, improper maintenance or unapproved modifications.

If you have any questions regarding your warranty rights and responsibilities, you should contact Triumph Motorcycles America Limited, Warranty Service Department, 100 Hartsfield Centre Parkway, Suite 200, Atlanta, GA 30354, or the California Air Resources Board at 9528 Telstar Avenue, El Monte, California 91731.

Triumph Motorcycles America Limited warrants to the first, and each subsequent owner, that the vehicle was designed and built so as to conform, at the time of sale, with the regulations of the California Air Resources Board and, at the time of manufacture, was free from defects in materials and workmanship which would cause the motorcycle not to meet the California Air Resources Board Standards.

This warranty period starts the date the motorcycle is delivered to the first retail purchaser or, if the motorcycle is placed in service as a demonstrator or company motorcycle prior to sale at retail, the date it is first placed in service.

The emission control system of each new Triumph motorcycle was designed, built and tested using only genuine Triumph Motorcycle parts and with these parts the motorcycle is certified as being in conformity with California emission control regulations.

WE RECOMMEND THAT ONLY GENUINE TRIUMPH MOTORCYCLE PARTS BE USED FOR MAINTENANCE REPAIR OR REPLACEMENT OF THE EMISSION CONTROL SYSTEM. However, if you are willing to pay for it yourself, you can have replacement or repair of your motorcycle's emission control system performed by any qualified repair establishment or individual using non-genuine parts.

Remember: Use of replacement parts which are not equal in quality to genuine Triumph parts may impair the effectiveness of the emission control system or otherwise damage your motorcycle. If other than genuine Triumph parts are used for maintenance, replacement or repair of

components affecting emission control, you should obtain written assurances that such non-Triumph parts are warranted by their manufacturer to be equal in quality to genuine Triumph Motorcycle parts in both performance and durability. The use of non-Triumph replacement parts does not invalidate the warranty, if any, on other components unless the non-Triumph parts cause damage to warranted parts. However, we recommend that you go only to any authorized Triumph Motorcycle dealer for repairs under warranty, that has factory-trained mechanics and genuine parts. However, in the case of an "emergency" (as defined below) where an authorized Triumph dealer is not reasonably available, you could have repairs performed at any available service establishment or by the owner, using any replacement part. A part not being available within 30 days, or a repair not being complete within 30 days constitutes an emergency. Triumph Motorcycles America Limited will reimburse the owner for such repairs, including diagnosis, only if it is established that the repairs are covered under this emission warranty. Triumph Motorcycles America Limited parts reimbursement, however, will not exceed our suggested retail price for all warranted parts replaced and our labor reimbursement will be limited to our recommended time allowances for emission system repairs at the geographically appropriate hourly labor rate.

To obtain reimbursement from Triumph Motorcycles America Limited for such emergency repairs, you must keep all failed parts and original receipts, marked "paid," so you can present them to an authorized Triumph dealer for their inspection. Triumph Motorcycles America Limited recommends that you bring your motorcycle to an authorized dealer for inspection to ensure that the emergency repairs were done properly.

WARRANTY

What is Covered by this Emission Warranty

The emission control system warranty covers the following "warranted parts" only:

- ▼ Fuel injection/engine management equipment including oxygen sensors
- ▼ Intake manifold
- ▼ Air cleaner box
- ▼ Spark advance/retard system
- ▼ Spark plugs (first 10,000 miles)
- ▼ Ignition coils
- ▼ Charcoal canister
- ▼ Cap, fuel tank
- ▼ Fuel/vapor separator (fuel tank)
- ▼ Vapor valve
- ▼ Rollover/pressure control valves
- ▼ If used on the above systems: hoses, clamps, fittings, tubing, sealing gaskets and mounting hardware.

What Is Not Covered By This Emission Warranty

The emission control system warranty does not cover:

Malfunctions in any "warranted parts" caused by any of the following; abuse, misuse, modification, alteration, tampering, disconnection, or improper or inadequate maintenance.

Damage resulting from accident, acts of nature or other events beyond the control of Triumph Motorcycles America Limited.

The repair or replacement of "warranted parts" which are scheduled for replacement prior to 18,641 miles (such as spark plugs, which are scheduled for replacement at 10,000 miles) once these parts have been replaced at the first replacement interval as part of required maintenance services.

Repairs and services performed by anyone other than an authorized Triumph dealer (except in case of emergency). The California Air Resources Board defines an "emergency" as an authorized dealer not being reasonably available or the lack of availability of "warranted parts" within a reasonable time period not to exceed 30 days.

Loss of time, inconvenience, loss of use of the motorcycle, or commercial loss.

Repairs on any motorcycle of which odometer mileage has been changed so that mileage cannot be really determined.

Triumph Overseas

If you are traveling abroad and require assistance or advice from a Triumph dealer, contact the subsidiary or importer for the country which you are visiting.

Subsidiary offices are listed below.

For an up to date list of authorized Triumph dealers and importers, visit www.triumphmotorcycles.co.uk.

Subsidiary Offices

Benelux

Triumph Netherlands

Tel: +31 725 41 0311

Email: Benelux@Triumph.co.uk

Brazil

Triumph Motorcycles Brazil Ltda

Tel: +55 11 3010 1010

Email: sac.triumph@europ-assistance.com.br

China

British Triumph (Shanghai) Trading Co., Ltd.

Room 302, Tower 11,

1250, Xinzha Road, Jingan District, Shanghai, PRC

200041

Tel: +86 21 6140 9180

Email: aftersales.china@triumphmotorcycles.com

Denmark/Finland/Norway/Sweden

Triumph Motorcycles AB

Tel: +46 8 680 68 00

Fax: +46 8 680 07 85

France

Triumph S.A.

Tel: +33 1 64 62 3838

Fax: +33 1 64 80 5828

Germany

Triumph Motorrad Deutschland GmbH

Tel: +49 6003 829090

Fax: +49 6003 8290927

India

Triumph Motorcycles (India) Private Limited

Tel: 1 800 3000 0051 (toll free)

Email: customer.care@triumphmotorcycles.in

Italy

Triumph Motorcycles srl

Tel: +39 02 93 454525

Fax: +39 02 93 582575

Japan

Triumph Motorcycles Japan K.K.

Tel: +81 3 6453 9810

Fax: +81 3 6453 9811

WARRANTY

Spain/Portugal

Triumph Motorcicletas España, S.L

Tel: +34 91 637 7475

Fax: +34 91 636 1134

Thailand

Triumph Thailand

Tel: +66(0)20170333

Fax: +66(0)20170330

United Kingdom/Eire

Triumph Motorcycles Ltd

Tel: +44 1455 45 5012

Fax: +44 1455 45 2211

USA

Triumph Motorcycles (America) Ltd

Tel: +1 678 854 2010

Fax: +1 678 854 8740

Caring for your Motorcycle

Triumph Motorcycles have taken great care in the selection of materials, plating and painting techniques so as to provide its customers with a quality cosmetic appearance allied to durability. However, motorcycles are often used in hostile environmental conditions and in these circumstances it is essential that the motorcycle is washed, dried and lost lubricity replaced to prevent discoloration particularly of plated and unplated metallic surfaces. Your dealer can provide further information and advice if required. Ultimately the appearance of your motorcycle will very much depend on the care it receives.

For further information in regards to caring for your motorcycle, refer to the Cleaning and Storage section of this Owner's Handbook.

Tiger 850 Sport and Tiger 900 GT - All Models**Dimensions, Weights and Performance**

A list of model specific dimensions, weights and performance figures is available from your authorized Triumph dealer, or on the Internet at www.triumph.co.uk.

Payload	Tiger 850 Sport and Tiger 900 GT - All Models
Maximum Payload	489 lb (222 kg)

Engine	Tiger 850 Sport and Tiger 900 GT - All Models
Type	In-line 3 cylinder
Displacement	54.19 cu in (888 cc)
Bore x Stroke	3.07 x 2.44 in (77.99 x 61.94 mm)
Compression Ratio	11.266:1
Cylinder Numbering	Left to Right
Cylinder Sequence	1 at left
Firing Order	1-3-2
Starting System	Electric Starter

Lubrication	Tiger 850 Sport and Tiger 900 GT - All Models
Lubrication	Pressure Lubrication (wet sump)
Engine Oil Capacities:	
Dry Fill	0.96 gallons (3.65 liters)
Oil/Filter Change	0.83 gallons (3.15 liters)
Oil Change Only	0.78 gallons (2.95 liters)

Cooling	Tiger 850 Sport and Tiger 900 GT - All Models
Coolant Type	Triumph HD4X Hybrid OAT coolant
Water/Antifreeze Ratio	50/50 (premixed as supplied by Triumph)
Coolant Capacity	0.59 gallons (2.25 liters)
Thermostat Opens (nominal)	190.4°F (88°C)

SPECIFICATIONS

Fuel System	Tiger 850 Sport and Tiger 900 GT - All Models
Type	Electronic Fuel Injection
Injectors	Solenoid Operated
Fuel Pump	Submerged Electric
Fuel Pressure (nominal)	51 lb/in ² (3.5 bar)

Fuel	Tiger 850 Sport and Tiger 900 GT - All Models
Type	91 RON unleaded
Tank Capacity (motorcycle upright)	5.28 gallons (20.0 liters)

Ignition	Tiger 850 Sport and Tiger 900 GT - All Models
Ignition System	Digital Inductive
Electronic Rev Limiter	10,000 r/min
Spark Plug	NGK CR9EK
Spark Plug Gap	0.03 in (0.7 mm)
Gap Tolerance	+0.002/-0.004 in (+0.05/-0.1 mm)

Transmission	Tiger 850 Sport and Tiger 900 GT - All Models
Transmission Type	6 Speed, Constant Mesh
Clutch Type	Wet, Multi-Plate
Primary Drive Ratio	1.652:1 (76/46)
Gear Ratios:	
1st	2.615:1 (34/13)
2nd	1.857:1 (39/21)
3rd	1.500:1 (36/24)
4th	1.286:1 (27/21)
5th	1.107:1 (31/28)
6th	0.967:1 (29/30)

Final Drive	Tiger 850 Sport and Tiger 900 GT - All Models
Final Drive	Chain
Final Drive Ratio	3.125:1 (50/16)
Chain Type	RK O-ring
Number of Links	122
20 Link Length	12.56 in (319 mm)
Drive Chain Vertical Movement Range	0.79 - 1.18 in (20 - 30 mm) - Tiger 900 GT (LRH)
	0.98 - 1.38 in (25 - 35 mm) - Tiger 850 Sport, Tiger 900 GT, Tiger 900 GT Pro

Approved Tires

A list of approved tires specific to these models is available from your authorized Triumph dealer, or on the Internet at www.triumph.co.uk.

Warning

Use the recommended tires ONLY in the combinations given.

Do not mix tires from different manufacturers or mix different specification tires from the same manufacturers as this may result in loss of motorcycle control and an accident.

Tires	Tiger 850 Sport and Tiger 900 GT - All Models
Tire Sizes:	
Front	100/90 - 19 M/C 57V
Rear	150/70 R17 M/C 69V
Tire Pressures (Cold):	
Front	36 lb/in ² (2.48 bar)
Rear	42 lb/in ² (2.89 bar)

SPECIFICATIONS

Warning

Tire pressures which have been reduced for off-road riding will impair on-road stability.

Always make sure that the tire pressures are set as described in the tire pressure table for on-road use.

Operation of the motorcycle with incorrect tire pressures may cause loss of motorcycle control leading to an accident.

Warning

The use of some mud and snow/dual purpose tires may result in reduced motorcycle stability.

Where these tires may be mounted, the permissible maximum speed will be indicated by a sticker, positioned so that it is clearly visible to the rider.

A list of approved tires, and any maximum speed restrictions, is available from your authorized Triumph dealer, or on the Internet at www.triumph.co.uk.

Operation of the motorcycle above the permissible maximum speed may result in loss of motorcycle control and an accident.

Electrical Equipment	Tiger 850 Sport and Tiger 900 GT - All Models
Battery Type	YTZ - 14S
Battery Rating	12 Volt, 11.2 Ah
Alternator	14 Volt, 34 Amp at 5,000 rpm
Headlight	LED
Tail/Brake Light	LED
Turn Signal Lights	LED
	12 Volt, 10 Watt - equipped on models for certain markets only
Fog Lights (if equipped)	LED

Frame	Tiger 850 Sport and Tiger 900 GT - All Models
Rake	24.6°
Trail	3.34 in (100 mm) - Tiger 900 GT (LRH)
	4.09 in (104 mm) - Tiger 850 Sport, Tiger 900 GT, Tiger 900 GT Pro

Tightening Torques	Tiger 850 Sport and Tiger 900 GT - All Models
Battery Terminals	39.8 lbf in (4.5 Nm)
Chain Adjuster Lock Nuts	11 lbf ft (15 Nm)
Chain Guard	80 lbf in (9 Nm)
Clutch Lever Nut	57.5 lbf in (6.5 Nm)
Oil Filter	89 lbf in (10 Nm)
Spark Plug	9 lbf ft (12 Nm)
Sump Plug	18 lbf ft (25 Nm)
Sump Guard Fasteners	53 lbf in (6 Nm)
Rear Wheel Spindle Nut	81 lbf ft (110 Nm)

Fluids and Lubricants	Tiger 850 Sport and Tiger 900 GT - All Models
Bearings and Pivots	Grease to NLGI 2 specification
Brake Fluid	DOT 4 brake fluid
Coolant	Triumph HD4X Hybrid OAT coolant (pre-mixed)
Drive Chain	Chain spray suitable for O-ring chains
Engine Oil	Semi or fully synthetic 10W/40 or 10W/50 motorcycle engine oil which meets specification API SH (or higher) and JASO MA, such as Castrol Power 1 Racing 4T 10W-40 (fully synthetic) engine oil, sold as Castrol Power RS Racing 4T 10W-40 (fully synthetic) in some countries.

This page intentionally left blank

Tiger 900 Rally and Tiger 900 Rally Pro

Dimensions, Weights and Performance

A list of model specific dimensions, weights and performance figures is available from your authorized Triumph dealer, or on the Internet at www.triumph.co.uk.

Payload**Tiger 900 Rally and Tiger 900 Rally Pro**

Maximum Payload

489 lb (222 kg)

Engine**Tiger 900 Rally and Tiger 900 Rally Pro**

Type

In-line 3 cylinder

Displacement

54.2 cu in (888 cc)

Bore x Stroke

3.07 x 2.44 in (77.99 x 61.94 mm)

Compression Ratio

11.266:1

Cylinder Numbering

Left to Right

Cylinder Sequence

1 at left

Firing Order

1-3-2

Starting System

Electric Starter

Lubrication**Tiger 900 Rally and Tiger 900 Rally Pro**

Lubrication

Pressure Lubrication (wet sump)

Engine Oil Capacities:

Dry Fill

0.96 gallons (3.65 liters)

Oil/Filter Change

0.83 gallons (3.15 liters)

Oil Change Only

0.78 gallons (2.95 liters)

Cooling**Tiger 900 Rally and Tiger 900 Rally Pro**

Coolant Type

Triumph HD4X Hybrid OAT coolant

Water/Antifreeze Ratio

50/50 (premixed as supplied by Triumph)

Coolant Capacity

0.59 gallons (2.25 liters)

Thermostat Opens (nominal)

190°F (88°C)

SPECIFICATIONS

Fuel System	Tiger 900 Rally and Tiger 900 Rally Pro
Type	Electronic Fuel Injection
Injectors	Solenoid Operated
Fuel Pump	Submerged Electric
Fuel Pressure (nominal)	50.8 lb/in ² (3.5 bar)

Fuel	Tiger 900 Rally and Tiger 900 Rally Pro
Type	91 RON unleaded
Tank Capacity (motorcycle upright)	5.28 gallons (20.0 liters)

Ignition	Tiger 900 Rally and Tiger 900 Rally Pro
Ignition System	Digital Inductive
Electronic Rev Limiter	10,000 r/min
Spark Plug	NGK CR9EK
Spark Plug Gap	0.03 in (0.7 mm)
Gap Tolerance	+0.002/-0.004 in (+0.05/-0.1 mm)

Transmission	Tiger 900 Rally and Tiger 900 Rally Pro
Transmission Type	6 Speed, Constant Mesh
Clutch Type	Wet, Multi-Plate
Primary Drive Ratio	1.652:1 (76/46)
Gear Ratios:	
1st	2.615:1 (34/13)
2nd	1.857:1 (39/21)
3rd	1.500:1 (36/24)
4th	1.286:1 (27/21)
5th	1.107:1 (31/28)
6th	0.967:1 (29/30)

Final Drive	Tiger 900 Rally and Tiger 900 Rally Pro
Final Drive	Chain
Final Drive Ratio	3.125:1 (50/16)
Chain Type	RK O-ring
Number of Links	122
20 Link Length	12.56 in (319 mm)
Drive Chain Vertical Movement Range	1.18 - 1.57 in (30 - 40 mm)

Approved Tires

A list of approved tires specific to these models is available from your authorized Triumph dealer, or on the Internet at www.triumph.co.uk.

Warning

Use the recommended tires ONLY in the combinations given.

Do not mix tires from different manufacturers or mix different specification tires from the same manufacturers as this may result in loss of motorcycle control and an accident.

Tires	Tiger 900 Rally and Tiger 900 Rally Pro
Tire Sizes:	
Front	90/90 - 21 M/C 54V
Rear	150/70 R17 M/C 69V
Tire Pressures (Cold) - all except Pirelli Scorpion™ Rally:	
Front	34 lb/in ² (2.34 bar)
Rear	42 lb/in ² (2.89 bar)
Tire Pressures (Cold) - Pirelli Scorpion™ Rally only:	
Front	34 lb/in ² (2.34 bar)
Rear	38 lb/in ² (2.62 bar)

SPECIFICATIONS

Warning

Tire pressures which have been reduced for off-road riding will impair on-road stability.

Always make sure that the tire pressures are set as described in the tire pressure table for on-road use.

Operation of the motorcycle with incorrect tire pressures may cause loss of motorcycle control leading to an accident.

Approved Mud and Snow/Dual Purpose Tires

A list of approved mud and snow/dual purpose tires specific to these models is available from your authorized Triumph dealer, or on the Internet at www.triumph.co.uk.

Warning

The use of mud and snow/dual purpose tires will result in reduced motorcycle stability.

Always operate a motorcycle equipped with mud and snow/dual purpose tires at reduced speeds. The permissible maximum speed is 60 mph (100 km/h). This is also shown on a warning sticker on the motorcycle.

Operation of the motorcycle above the permissible maximum speed may result in loss of motorcycle control and an accident.

Electrical Equipment

Tiger 900 Rally and Tiger 900 Rally Pro

Battery Type	YTZ - 14S
Battery Rating	12 Volt, 11.2 Ah
Alternator	14 Volt, 34 Amp at 5,000 rpm
Headlight	LED
Tail/Brake Light	LED
Turn Signal Lights	LED
	12 Volt, 10 Watt - equipped on models for certain markets only
Fog Lights (if equipped)	LED

Frame	Tiger 900 Rally and Tiger 900 Rally Pro
Rake	24.4°
Trail	4.56 in (115.9 mm)

Tightening Torques	Tiger 900 Rally and Tiger 900 Rally Pro
Battery Terminals	40 lbf in (4.5 Nm)
Chain Adjuster Lock Nuts	11 lbf ft (15 Nm)
Chain Guard	80 lbf in (9 Nm)
Clutch Lever Nut	57.5 lbf in (6.5 Nm)
Oil Filter	89 lbf in (10 Nm)
Spark Plug	9 lbf ft (12 Nm)
Sump Plug	18 lbf ft (25 Nm)
Rear Wheel Spindle Nut	81 lbf ft (110 Nm)

Fluids and Lubricants	Tiger 900 Rally and Tiger 900 Rally Pro
Bearings and Pivots	Grease to NLGI 2 specification
Brake Fluid	DOT 4 brake fluid
Coolant	Triumph HD4X Hybrid OAT coolant (pre-mixed)
Drive Chain	Chain spray suitable for XW-ring chains
Engine Oil	Semi or fully synthetic 10W/40 or 10W/50 motorcycle engine oil which meets specification API SH (or higher) and JASO MA, such as Castrol Power 1 Racing 4T 10W-40 (fully synthetic) engine oil, sold as Castrol Power RS Racing 4T 10W-40 (fully synthetic) in some countries.

This page intentionally left blank

Tiger 900 Bond Edition

Dimensions, Weights and Performance

A list of model specific dimensions, weights and performance figures is available from your authorized Triumph dealer, or on the Internet at www.triumph.co.uk.

Payload**Tiger 900 Bond Edition**

Maximum Payload

489 lb (222 kg)

Engine**Tiger 900 Bond Edition**

Type

In-line 3 cylinder

Displacement

54.19 cu in (888 cc)

Bore x Stroke

3.07 x 2.44 in (77.99 x 61.94 mm)

Compression Ratio

11.266:1

Cylinder Numbering

Left to Right

Cylinder Sequence

1 at left

Firing Order

1-3-2

Starting System

Electric Starter

Lubrication**Tiger 900 Bond Edition**

Lubrication

Pressure Lubrication (wet sump)

Engine Oil Capacities:

Dry Fill

0.96 gallons (3.65 liters)

Oil/Filter Change

0.83 gallons (3.15 liters)

Oil Change Only

0.78 gallons (2.95 liters)

Cooling**Tiger 900 Bond Edition**

Coolant Type

Triumph HD4X Hybrid OAT coolant

Water/Antifreeze Ratio

50/50 (premixed as supplied by Triumph)

Coolant Capacity

0.59 gallons (2.25 liters)

Thermostat Opens (nominal)

190.4°F (88°C)

SPECIFICATIONS

Fuel System	Tiger 900 Bond Edition
Type	Electronic Fuel Injection
Injectors	Solenoid Operated
Fuel Pump	Submerged Electric
Fuel Pressure (nominal)	51 lb/in ² (3.5 bar)

Fuel	Tiger 900 Bond Edition
Type	91 RON unleaded
Tank Capacity (motorcycle upright)	5.28 gallons (20.0 liters)

Ignition	Tiger 900 Bond Edition
Ignition System	Digital Inductive
Electronic Rev Limiter	10,000 r/min
Spark Plug	NGK CR9EK
Spark Plug Gap	0.03 in (0.7 mm)
Gap Tolerance	+0.002/-0.004 in (+0.05/-0.1 mm)

Transmission	Tiger 900 Bond Edition
Transmission Type	6 Speed, Constant Mesh
Clutch Type	Wet, Multi-Plate
Primary Drive Ratio	1.652:1 (76/46)
Gear Ratios:	
1st	2.615:1 (34/13)
2nd	1.857:1 (39/21)
3rd	1.500:1 (36/24)
4th	1.286:1 (27/21)
5th	1.107:1 (31/28)
6th	0.967:1 (29/30)

Final Drive	Tiger 900 Bond Edition
Final Drive	Chain
Final Drive Ratio	3.125:1 (50/16)
Chain Type	RK O-ring
Number of Links	122
20 Link Length	12.56 in (319 mm)
Drive Chain Vertical Movement Range	1.18 - 1.57 in (30 - 40 mm)

Approved Tires

A list of approved tires specific to these models is available from your authorized Triumph dealer, or on the Internet at www.triumph.co.uk.

Warning

Use the recommended tires ONLY in the combinations given.

Do not mix tires from different manufacturers or mix different specification tires from the same manufacturers as this may result in loss of motorcycle control and an accident.

Tires - Tiger 900 Bond Edition	Standard	Michelin Anakee Wild™
Tire Sizes:		
Front	90/90-21 M/C 54V	90/90-21 54R M+S
Rear	150/70 R17 M/C 69V	150/70R17 69R M+S
Tire Pressures (Cold)		
Front	34 lb/in ² (2.34 bar)	34 lb/in ² (2.34 bar)
Rear	42 lb/in ² (2.89 bar)	42 lb/in ² (2.89 bar)

SPECIFICATIONS

Warning

Tire pressures which have been reduced for off-road riding will impair on-road stability.

Always make sure that the tire pressures are set as described in the tire pressure table for on-road use.

Operation of the motorcycle with incorrect tire pressures may cause loss of motorcycle control leading to an accident.

Approved Mud and Snow/Dual Purpose Tires

A list of approved mud and snow/dual purpose tires specific to these models is available from your authorized Triumph dealer, or on the Internet at www.triumph.co.uk.

Warning

The use of mud and snow/dual purpose tires will result in reduced motorcycle stability.

Always operate a motorcycle equipped with mud and snow/dual purpose tires at reduced speeds. The permissible maximum speed is 60 mph (100 km/h). This is also shown on a warning sticker on the motorcycle.

Operation of the motorcycle above the permissible maximum speed may result in loss of motorcycle control and an accident.

Electrical Equipment

Tiger 900 Bond Edition

Battery Type	YTZ - 14S
Battery Rating	12 Volt, 11.2 Ah
Alternator	14 Volt, 34 Amp at 5,000 rpm
Headlight	LED
Tail/Brake Light	LED
Turn Signal Lights	LED
	12 Volt, 10 Watt - equipped on models for certain markets only
Fog Lights (if equipped)	LED

Frame	Tiger 900 Bond Edition
Rake	24.4°
Trail	4.56 in (115.9 mm)

Tightening Torques	Tiger 900 Bond Edition
Battery Terminals	39.8 lbf in (4.5 Nm)
Chain Adjuster Lock Nuts	11 lbf ft (15 Nm)
Chain Guard	80 lbf in (9 Nm)
Clutch Lever Nut	57.5 lbf in (6.5 Nm)
Oil Filter	89 lbf in (10 Nm)
Spark Plug	9 lbf ft (12 Nm)
Sump Plug	18 lbf ft (25 Nm)
Rear Wheel Spindle Nut	81 lbf ft (110 Nm)

Fluids and Lubricants	Tiger 900 Bond Edition
Bearings and Pivots	Grease to NLGI 2 specification
Brake Fluid	DOT 4 brake fluid
Coolant	Triumph HD4X Hybrid OAT coolant (pre-mixed)
Drive Chain	Chain spray suitable for XW-ring chains
Engine Oil	Semi or fully synthetic 10W/40 or 10W/50 motorcycle engine oil which meets specification API SH (or higher) and JASO MA, such as Castrol Power 1 Racing 4T 10W-40 (fully synthetic) engine oil, sold as Castrol Power RS Racing 4T 10W-40 (fully synthetic) in some countries.

This page intentionally left blank

- A**
- Accessories 123
 - Anti-lock Braking System (ABS) 116
 - Optimized Cornering ABS 117
 - Warning Light 116
- B**
- Battery 174
 - Charging 177
 - Discharge 176
 - Disposal 175
 - Installation 178
 - Maintenance 175
 - Removal 174
 - Storage 176
 - Brakes 150
 - Brake Lever Adjuster 37
 - Brake Wear Inspection 150
 - Braking 114
 - Breaking in New Pads and Discs 150
 - Disc Brake Fluid 152
 - Front Brake Fluid Adjustment 153
 - Front Brake Fluid Inspection 153
 - Light Switches 154
 - Optimized Cornering ABS 117
 - Pad Wear Compensation 151
 - Rear Brake Fluid Adjustment 154
 - Rear Brake Fluid Inspection 154
 - Breaking-In 107
- C**
- Cleaning
 - After Washing 190
 - Aluminum Items - not Lacquered or Painted 191
 - Black Chrome Items 192
 - Care of Leather Products 195
 - Chrome and Stainless Steel 191
 - Exhaust System 192
 - Frequency of Cleaning 188
 - Gloss Paintwork 190
 - Matt Paintwork 190
 - Preparation for Washing 188
 - Seat Care 193
 - Washing 189
 - Where to be Careful 189
 - Windshield 194
- Clutch** 145
 - Adjustment 145
 - Clutch Lever Adjuster 38
 - Inspection 145
- Cooling System** 141
 - Coolant Change 144
 - Cooling Level Adjustment 143
 - Cooling Level Inspection 142
 - Corrosion Inhibitors 141
 - Specifications 211, 217, 223
- Cruise Control**
- Activating 81
 - Adjusting the Set Speed 82
 - Cruise Control Adjust Switch 31
 - Deactivating 82
 - Resuming the Set Speed 83
- D**
- Daily Safety Checks 108
 - Daytime Running Lights (DRL) 47
 - Dimensions 211, 217, 223
 - Drive Chain 146
 - Free Movement Adjustment 148
 - Free Movement Inspection 147
 - Lubrication 146
 - Wear Inspection 149
- E**
- Electrical Accessory Socket
 - Front 106
 - Rear 106
 - Electrical Equipment
 - Specification 214, 220, 226
 - Engine
 - Moving Off 111
 - Serial Number 23
 - Specifications 211, 217, 223
 - Starting the Engine 111
 - Stopping the Engine 110
 - Engine Oil 136
 - Disposal of Oil and Filters 140
 - Low Oil Pressure Warning Light 43
 - Oil and Oil Filter Change 138

- Oil Level Inspection..... 138
- Specification and Grade 140
- F**
- Final Drive
 - Specifications..... 213, 219, 225
- Fluids
 - Specifications..... 215, 221, 227
- Frame
 - Specifications..... 214, 221, 227
- Front Suspension
 - Adjustment..... 157
 - Compression Damping Adjustment..... 160
 - Front Fork Inspection 162
 - Rebound Damping Adjustment 161
 - Setting Chart..... 157
 - Spring Preload Adjustment..... 159
- Fuel
 - Filling the Fuel Tank 93
 - Fuel Grade 90
 - Refueling..... 92
 - Specifications..... 212, 218, 224
 - System Specifications..... 212, 218, 224
- Fuel Tank
 - Filling..... 93
- Fuses..... 179
- G**
- Gears
 - Shifting Gears 112
- H**
- Hazards
 - Warning Lights..... 46
- Headlights
 - Adjustment..... 184
 - Daytime Running Lights (DRL) 184
 - Fog Lights..... 185
 - Replacement 184
- Heated Seats
 - Heated Seat Switch..... 35
- High Beam
 - Indicator Light..... 46
- High Speed Operation..... 120
- I**
- Ignition
 - Specifications..... 212, 218, 224
- Immobilizer
 - Indicator Light..... 43
- Instruments
 - Ambient Air Temperature 53
 - Bike Set Up Menu 62
 - Coolant Temperature Gage..... 52
 - Damping..... 79
 - Display Set Up Menu..... 66, 72
 - Display Styles..... 42
 - Frost Symbol..... 53
 - Fuel Gage..... 51
 - Gear Position Display 54
 - Information Tray 54
 - Instrument Displays Overview..... 39
 - Main Menu..... 58
 - Odometer 50, 75
 - Reset to Defaults..... 72
 - Riding Mode Configuration..... 60
 - Riding Mode Selection 57
 - Riding Modes 55, 61
 - Service 75
 - Speedometer..... 50
 - Suspension 79
 - Tachometer..... 51
 - TFT Display Warning Lights (5 inch)..... 40
 - TFT Display Warning Lights (7 inch)..... 41
 - Trip Set Up..... 64
 - Warning and Information Messages... 42, 49
- J**
- Joystick Button..... 33
- L**
- Left Handlebar Switches..... 31
 - Fog Lights Switch 34
 - Heated Grips Switch..... 33
 - Heated Seat Switch..... 35
 - High Beam Button..... 34
 - Horn Button..... 33
 - Joystick Button..... 33
 - MODE Button 32
 - Turn Signal Switch..... 32

- Lights 185
 - Hazards 46
- Loading 125
- Lubrication
 - Specifications 211, 217, 223
- M**
- Maintenance
 - Scheduled Maintenance 131
- Mirrors 186
- O**
- Off-road Use 05
- P**
- Parking 119
- Parts Identification 18, 20
 - Rider View 22
- Passengers 126
- Performance 211, 217, 223
- R**
- Rear Suspension
 - Rebound Damping Adjustment 167
 - Settings Charts 163, 164
 - Spring Preload Adjustment 166
- Right Handlebar Switches 29
 - Daytime Running Lights (DRL) Switch 31
 - Engine Stop Switch 30
 - Hazard Warning Lights 30
 - HOME Button 29
 - Starter Button 30
- S**
- Safety
 - Fuel and Exhaust Fumes 09
 - Helmet and Clothing 10
 - Maintenance and Equipment 14
 - Motorcycle 08
 - Parking 13
 - Parts and Accessories 13
 - Riding 10
- Seats
 - Heated Seats (if equipped) 100
 - Passenger Heated Seat 101
 - Passenger Seat 97
 - Passenger Seat Installation 98
 - Passenger Seat Removal 97
 - Rider Heated Seat 101
 - Rider's Seat 98
 - Rider's Seat Height Adjustment 99
 - Rider's Seat Removal 98
 - Rider's Seat Installation 99
 - Seat Care 96, 193
 - Seat Lock 96
 - Storage 102
- Stands 94
 - Center Stand 95
 - Side Stand 94
- Steering
 - Inspection 155
- Storage
 - Preparation after Storage 197
 - Preparation for Storage 196
- T**
- Tail Light
 - License Plate Light 185
- Throttle Control 35
- Tiger 900 GT (LRH) 06
- Tire Pressure Monitoring System (TPMS) 86
 - Replacement Tires 89
 - Sensor Batteries 89
 - Sensor Serial Number 88
 - Tire Pressure Warning Light 48, 87
 - Tire Pressures 89, 171
- Tires 169
 - Minimum Tread Depth 171
 - Replacement 89, 172
 - Specifications 213, 219, 225
 - Tire Inflation Pressures 170
 - Tire Wear 171
- Tool Kit 104
- Torque
 - Specifications 215, 221, 227
- Traction Control (TC) 84
 - Disabled Warning Light 45
 - Indicator Light 45
 - Optimized Cornering Traction Control 85
 - Settings 86
- Transmission

Specifications.....	212, 218, 224
Triumph Shift Assist (TSA).....	113
Turn Signal Lights.....	185
Bulb Unit.....	185
LED Unit.....	185
Turn Signals	
Warning Light.....	46

U

Universal Serial Bus (USB) Socket.....	105
--	-----

V

Vehicle Identification Number.....	23
------------------------------------	----

W

Warnings.....	04
Immobilizer and TPMS.....	235
Maintenance.....	05
Noise Control System.....	06
Owner's Handbook.....	03
Warning Label Locations.....	16, 17
Warning Lights.....	42
Weights.....	211, 217, 223
Wheels.....	156
Windshield.....	103
Adjustment.....	103
Cleaning.....	194

This page intentionally left blank

This section contains approval information that is required to be included in this Owner's Handbook.

FCC Statement

This device complies with part 15 of the Federal Communications Commission (FCC) Rules.

Operation is subject to the following two conditions:

1. This device may not cause harmful interference.
2. This device must accept any interference received, including interference that may cause undesired operation.

Changes or modifications to the device could void the user's authority to operate the equipment.

Canadian Approval

This device contains license-exempt transmitter(s)/receiver(s) that comply with Innovation, Science and Economic Development Canada's license-exempt RSS(s).

Operation is subject to the following two conditions:

1. This device may not cause interference.
2. This device must accept any interference, including interference that may cause undesired operation of the device.

Radio frequency radiation exposure information:

This equipment complies with radiation exposure limits set forth for an uncontrolled environment. This equipment should be installed and operated with minimum distance of 20 cm between the radiator and your body.